

# QUINT4-UPS/24DC/24DC/40

## Uninterruptible power supply

Data sheet  
107558\_en\_00

© PHOENIX CONTACT 2018-07-16



## 1 Description

The QUINT DC-UPS uninterruptible power supply enables continued supply of critical loads in the event of a power supply malfunction.

### Intelligent battery management

- IQ Technology: reliable determination of remaining service life and buffer time
- Automatic battery detection: Supports VRLA, VRLA-WTR, and LI-ION battery technologies
- Powerful battery charger with up to 5 A charging current

### Extended load management

- Energy monitoring: Monitors output and battery voltages and associated currents
- PC mode: reliable shutdown of the IPC in the event of a mains failure without data loss, and autostart of the IPC when the power returns
- Cold restart function: UPS startup even without mains power

### Communication interfaces

- Supports 1x USB with Modbus/RTU, 2x RJ45 with PROFINET, EtherNet/IP™ or EtherCAT® protocol.
- Integrated 2-port switch (daisy chain).
- Library of function blocks and device descriptions.

### Technical data (short form)

Input voltage	24 V DC
Input voltage range	18 V DC ... 30 V DC
Current consumption (I <sub>max</sub> )	51.2 A
Fixed connect threshold	
Undervoltage	22 V DC
Surge voltage	30 V DC
Output voltage range (grid, battery-dependent)	18 V DC ... 30 V DC
Output current (I <sub>N</sub> / I <sub>Stat. Boost</sub> / I <sub>Dyn. Boost</sub> / I <sub>SFB</sub> )	40 A / 45 A / 60 A (5 s) / 215 A (15 ms)
Output power (P <sub>N</sub> / P <sub>Stat. Boost</sub> / P <sub>Dyn. Boost</sub> )	960 W / 1080 W / 1440 W (5 s)
Efficiency	typ. 98 %
Nominal capacity (without additional charger)	7 Ah ... 135 Ah
Charging current (configurable)	max. 5 A
MTBF (IEC 61709, SN 29500)	> 1205000 h (40 °C)
Ambient temperature (operation)	-25 °C ... 70 °C -40 °C (startup type tested) > 60 °C Derating: 2.5 %/K
Dimensions W/H/D	47 mm / 130 mm / 125 mm
Weight	0.7 kg
<b>Order designation</b>	
QUINT4-UPS/24DC/24DC/40	no communication
QUINT4-UPS/24DC/24DC/40/USB	USB (Modbus/RTU)
QUINT4-UPS/24DC/24DC/40/PN	PROFINET
QUINT4-UPS/24DC/24DC/40/EIP	EtherNet/IP™
QUINT4-UPS/24DC/24DC/40/EC	EtherCAT®



All technical specifications are nominal values and refer to a room temperature of 25 °C and 70 % relative humidity at 100 m above sea level.

**2 Table of contents**

1 Description ..... 1

2 Table of contents ..... 2

3 Ordering data ..... 6

4 Technical data ..... 12

5 Symbols used ..... 24

6 Safety regulations and installation notes ..... 25

7 Design ..... 26

    7.1 Rating plate ..... 26

    7.2 Device connections and functional elements ..... 27

    7.3 Block diagram ..... 28

    7.4 Device dimensions ..... 29

8 Mounting/remove ..... 30

    8.1 Convection ..... 30

    8.2 Mounting position (Derating) ..... 30

    8.3 Installation height ..... 30

    8.4 Keep-out areas ..... 31

    8.5 Mounting the UPS ..... 31

    8.6 Removing the UPS ..... 32

    8.7 Retrofitting the universal DIN rail adapter ..... 32

        8.7.1 Disassembling the universal DIN rail adapter ..... 32

        8.7.2 Mounting the universal DIN rail adapter ..... 33

    8.8 Retrofitting the universal wall adapter ..... 33

        8.8.1 Mounting the UWA 182/52 universal wall adapter ..... 33

        8.8.2 Mounting the UWA 130 2-piece universal wall adapter ..... 34

9 Device connection terminal blocks / device interfaces ..... 34

    9.1 DC input terminal ..... 35

    9.2 DC output terminal blocks (buffered load) ..... 35

    9.3 Signal terminal blocks ..... 36

        9.3.1 +24 V DC (SGnd reference potential) ..... 36

        9.3.2 Floating switch contact ..... 36

        9.3.3 Digital outputs (DO) ..... 36

        9.3.4 Digital inputs (DI) ..... 36

        9.3.5 Digital/analog input (DI/AI) ..... 36

        9.3.6 SGnd (reference potential) ..... 36

    9.4 Battery terminals ..... 37

    9.5 Communication interface ..... 37

        9.5.1 USB communication interface ..... 37

        9.5.2 RJ45 communication interfaces ..... 38

    9.6 Securing the connection wiring ..... 39



10	Function elements .....	40
10.1	Operating element – rotary selector switch.....	40
10.1.1	UPS without communication interface.....	41
10.1.2	UPS with communication interface.....	41
10.2	Operating element – service button .....	42
10.3	Display elements .....	42
10.3.1	LED status indicators for device status .....	42
10.3.2	LED status indicators for charging status .....	42
10.3.3	LED status indicators for data traffic.....	42
11	System configuration .....	43
11.1	System prerequisites for the use of Phoenix Contact batteries.....	43
12	Operating states and basic functions .....	44
12.1	Initialization of UPS startup.....	45
12.1.1	Input supply.....	45
12.1.2	Cold restart (battery start) .....	45
12.1.3	Function of the service button (load default setting) .....	45
12.1.4	Signaling .....	46
12.2	Mains operation.....	46
12.2.1	Output/supply of the load .....	46
12.2.2	Remote .....	46
12.2.3	Function of the service button (service mode).....	47
12.2.4	Signaling .....	49
12.3	Charging.....	49
12.3.1	Charge Phoenix Contact battery - SOC is determined .....	50
12.3.2	Charge Phoenix Contact battery - SOC is known.....	50
12.3.3	Batteries from other manufacturers – SOC is not displayed .....	50
12.3.4	PS Boost.....	50
12.3.5	Function of the service button (service mode).....	51
12.3.6	Signaling .....	51
12.4	Battery operation .....	51
12.4.1	Functions of the rotary selector switch .....	51
12.4.2	Actuation thresholds .....	51
12.4.3	Output/supply of the load .....	51
12.4.4	Remote .....	52
12.4.5	Function of the service button .....	52
12.4.6	Signaling .....	52
12.5	Standby .....	52
12.5.1	Signaling .....	53
12.6	UPS off .....	53

13	Battery management system (BMS)	54
13.1	Battery charger	54
13.1.1	Charging characteristic	54
13.1.2	Battery charging time	54
13.1.3	Battery technologies	55
13.1.4	Lead-acid battery	55
13.1.5	Lithium battery	55
13.2	Batteries from other manufacturers	55
13.3	Battery storage	55
14	Interfaces	56
14.1	USB	56
14.2	PROFINET	56
14.2.1	Signaling	56
14.2.2	Phoenix Contact PC WORX 6	57
14.2.3	Siemens TIA portal	58
14.3	EtherNet/IP™	59
14.3.1	Signaling	59
14.3.2	Rockwell LogixDesigner	59
14.4	EtherCAT®	60
14.4.1	Signaling	60
14.4.2	Beckhoff TwinCAT 3	60
15	Application example	62
15.1	Wiring the signal level	62
15.1.1	Alarm, PS Boost	62
15.1.2	Alarm, PS Boost, Bat.-Mode, Ready	63
15.2	Parallel connection of batteries	64
16	Attachment – Register tables	65
16.1	Information	65
16.2	Configuration	65
16.3	Status	66
16.4	Battery data	68
16.5	Code Set Parameters 0x1040	72
16.6	Set Signaling Code DO 1 0x1042	73
16.7	Set Signalling Code DO 2 0x1044	74
16.8	Set Signalling Code DO 3 0x1046	75
16.9	Code Set Function Code DI 1 0x104A	75
16.10	Code Set Function Code DI 2 0x104B	76
16.11	Code Set User Installed Peripherie 0x1063	76
16.12	Code Set Mode Selector Switch 0x1074	76
16.13	Code Set Enable/Disable Function 0x1076	77
16.14	Code Status Functions 0x2000	77
16.15	Code Status Interface 0x2002	78

16.16	Code Status Installed Peripherie 0x2015 .....	78
16.17	Code Status Actual Alarms 0x3000 .....	79
16.18	Code Status Actual Warnings 0x3012 .....	80
16.19	Code Battery 1 Battery Type 0x4_07 .....	80
16.20	Code Battery 1 Charge Characteristic Type 0x4_17 .....	81
16.21	Code Battery Status Fuse 0x4_A5 .....	81



### 3 Ordering data

Description	Type	Order No.	Pcs./Pkt.
QUINT UPS with IQ Technology, for DIN rail mounting, input: 24 V DC, output: 24 V DC / 40 A, charging current: 5 A	QUINT4-UPS/24DC/24DC/40	2907077	1
QUINT UPS with IQ Technology, USB communication interface (Modbus/RTU), for DIN rail mounting, input: 24 V DC, output: 24 V DC / 40 A, charging current: 5 A	QUINT4-UPS/24DC/24DC/40/USB	2907078	1
QUINT UPS with IQ Technology, RJ45 communication interfaces (PROFINET), for DIN rail mounting, input: 24 V DC, output: 24 V DC / 40 A, charging current: 5 A	QUINT4-UPS/24DC/24DC/40/PN	2907079	1
QUINT UPS with IQ Technology, RJ45 communication interfaces (EtherNet/IP™), for DIN rail mounting, input: 24 V DC, output: 24 V DC / 40 A, charging current: 5 A	QUINT4-UPS/24DC/24DC/40/EIP	2907080	1
QUINT UPS with IQ Technology, RJ45 communication interfaces (EtherCAT®), for DIN rail mounting, input: 24 V DC, output: 24 V DC / 40 A, charging current: 5 A	QUINT4-UPS/24DC/24DC/40/EC	2907081	1

Accessories	Type	Order No.	Pcs./Pkt.
Energy storage device, lead AGM, VRLA technology, 24 V DC, 7.2 Ah, tool-free battery replacement, automatic detection, and communication with QUINT UPS-IQ	UPS-BAT/VRLA/24DC/7.2AH	2320319	1
Energy storage device, lead AGM, VRLA technology, 24 V DC, 12 Ah, tool-free battery replacement, automatic detection, and communication with QUINT UPS-IQ	UPS-BAT/VRLA/24DC/12AH	2320322	1
Energy storage device, lead AGM, VRLA technology, 24 V DC, 38 Ah, automatic detection, and communication with QUINT UPS-IQ	UPS-BAT/VRLA/24DC/38AH	2320335	1
Energy storage device, lead AGM, VRLA technology, 24 V DC, 13 Ah, tool-free battery replacement, automatic detection, and communication with QUINT UPS-IQ	UPS-BAT/VRLA-WTR/24DC/13AH	2320416	1
Energy storage device, lead AGM, VRLA technology, 24 V DC, 26 Ah, tool-free battery replacement, automatic detection, and communication with QUINT UPS-IQ	UPS-BAT/VRLA-WTR/24DC/26AH	2320429	1
Energy storage device, LI-ION technology, 24 V DC, 120 Wh, for ambient temperatures of -20°C ... 60°C, automatic detection and communication with QUINT UPS-IQ	UPS-BAT/LI-ION/24DC/120WH	2320351	1
Energy storage device, LI-ION technology, 24 V DC, 924 Wh, for ambient temperatures of -25 °C ... 60 °C, automatic detection and communication with QUINT UPS-IQ	UPS-BAT/LI-ION/24DC/924WH	2908232	1



The range of accessories is being continuously extended. The current range of accessories can be found in the download area for the product.

<b>QUINT4-UPS/24DC/24DC/40/USB ( 2907078 )</b>			
<b>Accessories</b>	<b>Type</b>	<b>Order No.</b>	<b>Pcs./Pkt.</b>
Used for communication between an industrial PC and Phoenix Contact devices with USB-Mini-B connection.	MINI-SCREW-USB-DATACABLE	2908217	1
Energy storage device, lead AGM, VRLA technology, 24 V DC, 7.2 Ah, tool-free battery replacement, automatic detection, and communication with QUINT UPS-IQ	UPS-BAT/VRLA/24DC/7.2AH	2320319	1
Energy storage device, lead AGM, VRLA technology, 24 V DC, 12 Ah, tool-free battery replacement, automatic detection, and communication with QUINT UPS-IQ	UPS-BAT/VRLA/24DC/12AH	2320322	1
Energy storage device, lead AGM, VRLA technology, 24 V DC, 38 Ah, automatic detection, and communication with QUINT UPS-IQ	UPS-BAT/VRLA/24DC/38AH	2320335	1
Energy storage device, lead AGM, VRLA technology, 24 V DC, 13 Ah, tool-free battery replacement, automatic detection, and communication with QUINT UPS-IQ	UPS-BAT/VRLA-WTR/24DC/13AH	2320416	1
Energy storage device, lead AGM, VRLA technology, 24 V DC, 26 Ah, tool-free battery replacement, automatic detection, and communication with QUINT UPS-IQ	UPS-BAT/VRLA-WTR/24DC/26AH	2320429	1
Energy storage device, LI-ION technology, 24 V DC, 120 Wh, for ambient temperatures of -20°C ... 60°C, automatic detection and communication with QUINT UPS-IQ	UPS-BAT/LI-ION/24DC/120WH	2320351	1
Energy storage device, LI-ION technology, 24 V DC, 924 Wh, for ambient temperatures of -25 °C ... 60 °C, automatic detection and communication with QUINT UPS-IQ	UPS-BAT/LI-ION/24DC/924WH	2908232	1



<b>QUINT4-UPS/24DC/24DC/40/PN ( 2907079 )</b>			
<b>Accessories</b>	<b>Type</b>	<b>Order No.</b>	<b>Pcs./Pkt.</b>
Energy storage device, lead AGM, VRLA technology, 24 V DC, 7.2 Ah, tool-free battery replacement, automatic detection, and communication with QUINT UPS-IQ	UPS-BAT/VRLA/24DC/7.2AH	2320319	1
Energy storage device, lead AGM, VRLA technology, 24 V DC, 12 Ah, tool-free battery replacement, automatic detection, and communication with QUINT UPS-IQ	UPS-BAT/VRLA/24DC/12AH	2320322	1
Energy storage device, lead AGM, VRLA technology, 24 V DC, 38 Ah, automatic detection, and communication with QUINT UPS-IQ	UPS-BAT/VRLA/24DC/38AH	2320335	1
Energy storage device, lead AGM, VRLA technology, 24 V DC, 13 Ah, tool-free battery replacement, automatic detection, and communication with QUINT UPS-IQ	UPS-BAT/VRLA-WTR/24DC/13AH	2320416	1
Energy storage device, lead AGM, VRLA technology, 24 V DC, 26 Ah, tool-free battery replacement, automatic detection, and communication with QUINT UPS-IQ	UPS-BAT/VRLA-WTR/24DC/26AH	2320429	1
Energy storage device, LI-ION technology, 24 V DC, 120 Wh, for ambient temperatures of -20°C ... 60°C, automatic detection and communication with QUINT UPS-IQ	UPS-BAT/LI-ION/24DC/120WH	2320351	1
Energy storage device, LI-ION technology, 24 V DC, 924 Wh, for ambient temperatures of -25 °C ... 60 °C, automatic detection and communication with QUINT UPS-IQ	UPS-BAT/LI-ION/24DC/924WH	2908232	1

<b>QUINT4-UPS/24DC/24DC/40/EIP ( 2907080 )</b>			
<b>Accessories</b>	<b>Type</b>	<b>Order No.</b>	<b>Pcs./Pkt.</b>
Energy storage device, lead AGM, VRLA technology, 24 V DC, 7.2 Ah, tool-free battery replacement, automatic detection, and communication with QUINT UPS-IQ	UPS-BAT/VRLA/24DC/7.2AH	2320319	1
Energy storage device, lead AGM, VRLA technology, 24 V DC, 12 Ah, tool-free battery replacement, automatic detection, and communication with QUINT UPS-IQ	UPS-BAT/VRLA/24DC/12AH	2320322	1
Energy storage device, lead AGM, VRLA technology, 24 V DC, 38 Ah, automatic detection, and communication with QUINT UPS-IQ	UPS-BAT/VRLA/24DC/38AH	2320335	1
Energy storage device, lead AGM, VRLA technology, 24 V DC, 13 Ah, tool-free battery replacement, automatic detection, and communication with QUINT UPS-IQ	UPS-BAT/VRLA-WTR/24DC/13AH	2320416	1
Energy storage device, lead AGM, VRLA technology, 24 V DC, 26 Ah, tool-free battery replacement, automatic detection, and communication with QUINT UPS-IQ	UPS-BAT/VRLA-WTR/24DC/26AH	2320429	1
Energy storage device, LI-ION technology, 24 V DC, 120 Wh, for ambient temperatures of -20°C ... 60°C, automatic detection and communication with QUINT UPS-IQ	UPS-BAT/LI-ION/24DC/120WH	2320351	1
Energy storage device, LI-ION technology, 24 V DC, 924 Wh, for ambient temperatures of -25 °C ... 60 °C, automatic detection and communication with QUINT UPS-IQ	UPS-BAT/LI-ION/24DC/924WH	2908232	1

**QUINT4-UPS/24DC/24DC/40/EC ( 2907081 )**



Accessories	Type	Order No.	Pcs./Pkt.
Energy storage device, lead AGM, VRLA technology, 24 V DC, 7.2 Ah, tool-free battery replacement, automatic detection, and communication with QUINT UPS-IQ	UPS-BAT/VRLA/24DC/7.2AH	2320319	1
Energy storage device, lead AGM, VRLA technology, 24 V DC, 12 Ah, tool-free battery replacement, automatic detection, and communication with QUINT UPS-IQ	UPS-BAT/VRLA/24DC/12AH	2320322	1
Energy storage device, lead AGM, VRLA technology, 24 V DC, 38 Ah, automatic detection, and communication with QUINT UPS-IQ	UPS-BAT/VRLA/24DC/38AH	2320335	1
Energy storage device, lead AGM, VRLA technology, 24 V DC, 13 Ah, tool-free battery replacement, automatic detection, and communication with QUINT UPS-IQ	UPS-BAT/VRLA-WTR/24DC/13AH	2320416	1
Energy storage device, lead AGM, VRLA technology, 24 V DC, 26 Ah, tool-free battery replacement, automatic detection, and communication with QUINT UPS-IQ	UPS-BAT/VRLA-WTR/24DC/26AH	2320429	1
Energy storage device, LI-ION technology, 24 V DC, 120 Wh, for ambient temperatures of -20°C ... 60°C, automatic detection and communication with QUINT UPS-IQ	UPS-BAT/LI-ION/24DC/120WH	2320351	1
Energy storage device, LI-ION technology, 24 V DC, 924 Wh, for ambient temperatures of -25 °C ... 60 °C, automatic detection and communication with QUINT UPS-IQ	UPS-BAT/LI-ION/24DC/924WH	2908232	1



EtherCAT® is a registered trademark and patented technology, licensed by Beckhoff Automation GmbH, Germany.



## 4 Technical data

Input data	
	Unless otherwise stated, all data applies for 25°C ambient temperature, 24 V DC input voltage, and nominal output current ( $I_N$ ).
	The specified technical data is valid for all QUINT DC-UPS uninterruptible power supplies of performance class 40A. The additional note <i>configurable</i> identifies the technical data that can be configured on a UPS with communication interface. Configuration in the network can be performed via communication interface or via the UPS-CONF software (Order No. 2320403).
Input voltage	24 V DC
Input voltage range	18 V DC ... 30 V DC
Electric strength, max.	35 V DC (Protected against polarity reversal)
Fixed connect threshold	
Undervoltage	22 V DC
Surge voltage	30 V DC
Voltage drop, input/output	0.5 V DC
Current draw	
$I_N$ ( $U_N$ , $I_{Out} = I_N$ , $I_{Charge} = 0$ )	40.1 A
$I_{Max}$ ( $U_N$ , $I_{Out} = I_{Stat.Boost}$ , $I_{Charge} = max$ )	51.2 A
$I_{No-Load}$ ( $U_N$ , $I_{Out} = 0$ , $I_{Charge} = 0$ )	50 mA
$I_{Charge}$ ( $U_N$ , $I_{Out} = 0$ , $I_{Charge} = max$ )	6.1 A
Power consumption	
$P_N$ ( $U_N$ , $I_{Out} = I_N$ , $I_{Charge} = 0$ )	965 W
$P_{Max}$ ( $U_N$ , $I_{Out} = I_{stat.Boost}$ , $I_{Charge} = max$ )	1120 W
$P_{No-Load}$ ( $U_N$ , $I_{Out} = 0$ , $I_{Charge} = 0$ )	1.3 W
$P_{Charge}$ ( $U_N$ , $I_{Out} = 0$ , $I_{Charge} = max$ )	147 W
Inrush surge current	$\leq 9$ A ( $\leq 4$ ms)
Internal input fuse	no
Switch-on time	max. 3 s
Switch-on time during battery operation (Bat.-Start)	8 s
Input connection data	
Connection method	Screw connection
Conductor cross section, solid	0.5 mm <sup>2</sup> ... 16 mm <sup>2</sup>
Conductor cross section, flexible	0.5 mm <sup>2</sup> ... 16 mm <sup>2</sup>
Stranded conductor cross section with ferrule	0.5 mm <sup>2</sup> ... 16 mm <sup>2</sup>
Cross section AWG	8 ... 6
Stripping length	10 mm
Tightening torque	1.2 Nm ... 1.5 Nm

Output data (mains operation)	
Output voltage	24 V DC ( $U_{OUT} = U_{IN} - 0.5 \text{ V DC}$ )
Output voltage range	18 V DC ... 30 V DC ( $U_{OUT} = U_{IN} - 0.5 \text{ V DC}$ )
Output current	
$I_N$	40 A
$I_{Stat.Boost}$	45 A
$I_{Dyn.Boost}$	60 A (5 s)
$I_{SFB}$	215 A (15 ms)
Output power	
$P_N (U_N, I_{Out} = I_N, I_{Charge} = 0)$	960 W
$P_{Stat.Boost} (U_N, I_{Out} = I_{Stat.Boost}, I_{Charge} = 0)$	1080 W
$P_{Dyn.Boost} (U_N, I_{Out} = I_{Dyn.Boost}, I_{Charge} = 0)$	1440 W (5 s)
Power dissipation	
No load ( $U_N, I_{Out} = 0, I_{Charge} = 0$ )	3 W
Nominal load ( $U_N, I_{Out} = I_N, I_{Charge} = 0$ )	24 W
Short-circuit-proof	yes
No-load proof	yes

Output data (battery operation)	
Output voltage	24 V DC ( $U_{OUT} = U_{BAT} - 0.5 \text{ V DC}$ )
Output voltage range	19 V DC ... 28 V DC ( $U_{OUT} = U_{BAT} - 0.5 \text{ V DC}$ )
Output current	
$I_N$	40 A
$I_{Stat.Boost}$	45 A
$I_{Dyn.Boost}$	60 A (5 s)
$I_{SFB}$	215 A (15 ms)
Output power	
$P_N (U_N, I_{Out} = I_N, I_{Charge} = 0)$	960 W
$P_{Stat.Boost} (U_N, I_{Out} = I_{Stat.Boost}, I_{Charge} = 0)$	1080 W
$P_{Dyn.Boost} (U_N, I_{Out} = I_{Dyn.Boost}, I_{Charge} = 0)$	1440 W (5 s)
Power dissipation	
No load ( $U_N, I_{Out} = 0, I_{Charge} = 0$ )	2 W
Nominal load ( $U_N, I_{Out} = I_N, I_{Charge} = 0$ )	25 W
Short-circuit-proof	yes
No-load proof	yes

Output connection data	
Connection method	Screw connection
Conductor cross section, solid	0.5 mm <sup>2</sup> ... 16 mm <sup>2</sup>
Conductor cross section, flexible	0.5 mm <sup>2</sup> ... 16 mm <sup>2</sup>
Stranded conductor cross section with ferrule	0.5 mm <sup>2</sup> ... 16 mm <sup>2</sup>
Conductor cross section AWG	8 ... 6
Stripping length	10 mm
Tightening torque	1.2 Nm ... 1.5 Nm

**Energy storage ( Battery )**

Charge characteristic curve	IU <sub>0</sub> U
Nominal voltage U <sub>N</sub>	24 V DC
End-of-charge voltage (temperature-compensated)	25 V DC ... 32 V DC
End-of-charge voltage (configurable)	27.6 V DC
Temperature compensation (configurable)	42 mV/K
Temperature sensor	yes
Charging current (configurable)	max. 5 A
Deep discharge protection (configurable)	19.2 V DC
Battery technology	VRLA, VRLA-WTR, LI-ION
IQ-Technology	yes
Nominal capacity (without additional charger)	7 Ah ... 135 Ah
Charging time	500 min. (38 Ah)
Buffer time ( I <sub>N</sub> )	33 min. (38 Ah)
Can be connected in parallel	Yes, 5 (observe line protection)
Can be connected in series	no

**Output connection battery**

Connection method	Screw connection
Conductor cross section, solid	0.5 mm <sup>2</sup> ... 16 mm <sup>2</sup>
Conductor cross section, flexible	0.5 mm <sup>2</sup> ... 16 mm <sup>2</sup>
Stranded conductor cross section with ferrule	0.5 mm <sup>2</sup> ... 16 mm <sup>2</sup>
Conductor cross section AWG	24 ... 16
Stripping length	10 mm
Tightening torque	1.2 Nm ... 1.5 Nm



<b>Alarm signal state</b>	
Connection labeling	3.2, 3.3
Switch contact (floating)	OptoMOS
State (configurable)	Group alarm
State condition (configurable)	Alarm threshold
Switching voltage	max. 30 V AC/DC
Current carrying capacity	max. 100 mA
State - signal assignment	NC (Normally Closed)
LED status indicator	Red (Alarm)

<b>Bat.-Mode signal state</b>	
Connection labeling	3.4 (+)
Channel	DO (digital output)
Semiconductor output	MOSFET
State (configurable)	Bat.-Mode
State condition (configurable)	$U_{IN} < 18 \text{ V DC}$ , $U_{IN} > 30 \text{ V DC}$ , Bat.-Start
DO (digital output)	
Output voltage	19 V DC ... 28 V DC (buffered)
Output can be loaded	max. 20 mA
State - signal assignment	active - high
Reference potential	3.9 (SGnd, identical to 1.2, 2.2, 4.2)
LED status indicator	Yellow (Bat.-Mode)

<b>Ready signal state</b>	
Connection labeling	3.5 (+)
Channel	DO (digital output)
Semiconductor output	MOSFET
State (configurable)	Ready
State condition (configurable)	SOC = 100 %
DO (digital output)	
Output voltage	19 V DC ... 28 V DC (buffered)
Output can be loaded	max. 20 mA
State - signal assignment	active - high
Reference potential	3.9 (SGnd, identical to 1.2, 2.2, 4.2)
LED status indicator	Green (SOC charging state)

Remote signal state	
Connection labeling	3.6 (+)
Channel	DI (digital input)
State (configurable)	Disconnection
State condition	Low level
DI (Digital input)	
Low signal	Input connected with SGnd (3.9) or <5 V DC
High signal	Input not connected or connected with 13 ... 30 V DC
Signal - state assignment	low - active
Reference potential	3.9 (SGnd, identical to 1.2, 2.2, 4.2)
LED status indicator	Yellow (Bat.-Mode)
PS Boost signal state	
Connection labeling	3.7 (+)
Channel (configurable)	DI (digital input) default, AI (analog input)
State (configurable)	Charging current reduced
State condition	Low level
DI (Digital input)	
Low signal	Input connected with SGnd (3.9), <5 V DC or not connected
High signal	Input connected with 13 ... 30 V DC
Signal - state assignment	low - active
Reference potential	3.9 (SGnd, identical to 1.2, 2.2, 4.2)
AI (analog input)	
Unit signal	I (mA)
Current signal	4 mA ... 20 mA (Offset zero point)
Load R <sub>B</sub>	390 Ω
Reference potential	3.9 (SGnd, identical to 1.2, 2.2, 4.2)
Bat.-Start signal state	
Connection labeling	3.8 (+)
Channel	DI (digital input)
State	Bat.-Mode
State condition	Low level (30 ms)
DI (Digital input)	
Low signal	Input connected with SGnd (3.9) or <U <sub>Bat</sub>
High signal	Input not connected or connected with >U <sub>Bat</sub>
Signal - state assignment	low - active
Reference potential	3.9 (SGnd, identical to 1.2, 2.2, 4.2)
LED status indicator	Yellow (Bat.-Mode)

**Signal supply 24 V DC, 20 mA, SGnd**

Connection labeling	3.1 (+), 3.9 (SGnd)
Output voltage	24 V DC
Output can be loaded	max. 20 mA
Reference potential	3.9 (SGnd, identical to 1.2, 2.2, 4.2)

**Signal connection data**

Connection method	Push-in technology
Conductor cross section, solid	0.2 mm <sup>2</sup> ... 1 mm <sup>2</sup>
Conductor cross section, flexible	0.2 mm <sup>2</sup> ... 1 mm <sup>2</sup>
Conductor cross section flexible, with ferrule (plastic sleeve)	0.2 mm <sup>2</sup> ... 0.75 mm <sup>2</sup>
Conductor cross section flexible, without ferrule (plastic sleeve)	0.75 mm <sup>2</sup> ... 0.2 mm <sup>2</sup>
Conductor cross section AWG	24 ... 16
Strip length	8 mm

**QUINT4-UPS/24DC/24DC/40/USB ( 2907078 )**

**Data interface**

Interface designation	USB (Modbus/RTU)
Number of interfaces	1
Connection method	MINI-USB Type B
Locking	Screw
Transmission physics	USB 2.0
Topology	Point-to-point
Transmission speed	9600 baud ... 115200 baud (Default: 115200 baud)
Transmission length	max. 5 m
Access time	≤ 2 s
Chipset	Silicon Labs CP210x
Electrical isolation	Yes, UL approved

QUINT4-UPS/24DC/24DC/40/PN ( 2907079 )	
Data interface	
Interface designation	PROFINET
Number of interfaces	2
Connection method	RJ45
Locking	Locking clip
Transmission physics	Twisted-Pair
Features	Autonegotiation , Autocrossing , Autopolarity , full duplex
Topology	Star , Line
Transmission speed	100 Mbps
Transmission length	max. 100 m
Cycle time	1 ms (RT)
Access time	≤ 2 s
Standards	IEEE 802.3 , IEC 61158 , IEC 61784-2
Protocols supported	PROFINET , LLDP
Chipset	Renesas TPS-1
Electrical isolation	yes
Device identification Type	QUINT4-UPS
Device name After configuration	QUINT4-UPS/24DC/24DC/40A
Device ID	0142 <sub>hex</sub>
Vendor ID	00B0 <sub>hex</sub>

QUINT4-UPS/24DC/24DC/40/EIP ( 2907080 )	
Data interface	
Interface designation	EtherNet/IP™
Number of interfaces	2
Connection method	RJ45 socket
Locking	Locking clip
Transmission physics	Twisted-Pair
Features	Autonegotiation , Autocrossing , Half- or full-duplex , automatic recognition Optional: manually adjustable
Topology	Star , Line
Transmission speed	10 Mbps ... 100 Mbps
Transmission length	max. 100 m
Cycle time	30 ms (Default)
Access time	≤ 2 s
Protocols supported	EtherNet/IP™ (Explicit Messaging, Implicit Messaging) , BootP , DHCP , DLR
Chipset	Renesas R-IN32M3
Electrical isolation	yes
Device identification	
Type	QUINT4-UPS/24DC/24DC/40A
Device name	
Default	QUINT4UPS24DC24DC40EIP
Device ID	1FF8 <sub>hex</sub>
Vendor ID	232hex



**QUINT4-UPS/24DC/24DC/40/EC ( 2907081 )**

**Data interface**

Interface designation	EtherCAT®
Number of interfaces	2
Connection method	RJ45
Locking	Locking clip
Transmission physics	Twisted-Pair
Features	Autonegotiation , Autocrossing , Half- or full-duplex , automatic recognition
Topology	Ring , Line
Transmission speed	100 Mbps
Transmission length	max. 100 m
Cycle time	< 100 µs
Access time	≤ 2 s
Protocols supported	CoE
Chipset	Renesas R-IN32M3
Electrical isolation	yes
Device identification	
Type	QUINT4-UPS/24DC/24DC/40A
Device ID	2C5b74 <sub>hex</sub>
Vendor ID	84 <sub>hex</sub>

**General data**

Inflammability class in acc. with UL 94 (housing / terminal blocks)	V0
Weight	0.7 kg
UPS connection in parallel	no
UPS connection in series	no

**Housing**

Degree of protection	IP20
Protection class	III (Without PE)
Mounting type	DIN rail mounting
Hood version	Stainless steel X6Cr17
Side element version	Aluminum AlMg3
Dimensions W / H / D (state of delivery)	47 mm / 130 mm / 125 mm
Dimensions W / H / D (90° turned)	123 mm / 130 mm / 49 mm

**Degree of efficiency**

QUINT4-UPS/24DC/24DC/40	2907077	no communication	typ. 98 %
QUINT4-UPS/24DC/24DC/40/USB	2907078	USB (Modbus/RTU)	typ. 98 %
QUINT4-UPS/24DC/24DC/40/PN	2907079	PROFINET	typ. 97 %
QUINT4-UPS/24DC/24DC/40/EIP	2907080	EtherNet/IP™	typ. 97 %
QUINT4-UPS/24DC/24DC/40/EC	2907081	EtherCAT®	typ. 97 %

<b>Ambient conditions</b>	
Ambient temperature (operation)	-25 °C ... 70 °C (> 60 °C Derating: 2.5 %/K)
Ambient temperature (start-up type tested)	-40 °C
Ambient temperature (storage/transport)	-40 °C ... 85 °C
Max. permissible relative humidity (operation)	≤ 95 % (at 25 °C, non-condensing)
Installation height	≤ 4000 m
Climatic class	3K3 (EN 60721)
Vibration (operation)	2.3g
Shock	18 ms, 30g, in each space direction (according to IEC 60068-2-27)
Degree of pollution	2
Overvoltage category	
EN 61010-1	II (≤ 4000 m)
EN 61010-2-201	II (≤ 4000 m)

**QUINT4-UPS/24DC/24DC/40 ( 2907077 )**

<b>Reliability</b>	
MTBF (IEC 61709, SN 29500)	> 1980000 h (25 °C) > 1205000 h (40 °C) > 604200 h (60 °C)

**QUINT4-UPS/24DC/24DC/40/USB ( 2907078 )**

<b>Reliability</b>	
MTBF (IEC 61709, SN 29500)	> 1376000 h (25 °C) > 888400 h (40 °C) > 467600 h (60 °C)

**QUINT4-UPS/24DC/24DC/40/PN ( 2907079 )**

<b>Reliability</b>	
MTBF (IEC 61709, SN 29500)	> 1151000 h (25 °C) > 718500 h (40 °C) > 365200 h (60 °C)

**QUINT4-UPS/24DC/24DC/40/EIP ( 2907080 )**

<b>Reliability</b>	
MTBF (IEC 61709, SN 29500)	> 1151000 h (25 °C) > 718500 h (40 °C) > 365200 h (60 °C)

**QUINT4-UPS/24DC/24DC/40/EC ( 2907081 )**

<b>Reliability</b>	
MTBF (IEC 61709, SN 29500)	1151000 h (25 °C) > 718500 h (40 °C) > 365200 h (60 °C)

**Standards**

SELV	IEC 61010-1 (SELV) IEC 61010-2-201 (PELV)
------	--

**Approvals**

UL	UL/C-UL Listed UL 61010-1 UL/C-UL Listed UL 61010-2-201 UL/C-UL Listed ANSI/ISA-12.12.01 Class I, Division 2, Groups A, B, C, D T4 (Hazardous Location)
CSA	CAN/CSA-C22.2 No. 61010-1-12 CAN/CSA-IEC 61010-2-201 CAN/CSA-C22.2 No. 213 Class I, Division 2, Groups A, B, C, D T4 (Hazardous Location)
CB Scheme	IEC 61010-1 IEC 61010-2-201

 Current approvals/permissions for the product can be found in the download area under [phoenixcontact.net/products](http://phoenixcontact.net/products)

**Electromagnetic compatibility / Conformance with EMC Directive 2014/30/EU**

**Noise emission according to EN 61000-6-3 (residential and commercial)**

**Immunity according to EN 61000-6-2 (industrial)**

CE basic standard	Minimum normative requirements of EN 61000-6-2 (CE) (immunity for industrial environments)	Higher requirements in practice (covered)
Electrostatic discharge EN 61000-4-2		
Housing contact discharge	4 kV (Test Level 2)	8 kV (Test Level 4)
Housing air discharge	8 kV (Test Level 3)	15 kV (Test Level 4)
Comments	Criterion B	Criterion A
Electromagnetic HF field EN 61000-4-3		
Frequency range	80 MHz ... 1 GHz	80 MHz ... 1 GHz
Test field strength	10 V/m (Test Level 3)	20 V/m (Test Level 3)
Frequency range	1.4 GHz ... 2 GHz	1 GHz ... 6 GHz
Test field strength	3 V/m (Test Level 2)	10 V/m (Test Level 3)
Frequency range	2 GHz ... 2.7 GHz	1 GHz ... 6 GHz
Test field strength	1 V/m (Test Level 1)	10 V/m (Test Level 3)
Comments	Criterion A	Criterion A

Immunity according to EN 61000-6-2 (industrial)			
CE basic standard		Minimum normative requirements of EN 61000-6-2 (CE) (immunity for industrial environments)	Higher requirements in practice (covered)
Fast transients (burst) EN 61000-4-4			
	Input	2 kV (Test Level 3 - asymmetrical)	4 kV (Test Level 4 - asymmetrical)
	Output	2 kV (Test Level 3 - asymmetrical)	4 kV (Test Level 4 - asymmetrical)
	Signal	1 kV (Test Level 3 - asymmetrical)	4 kV (Test Level 4 - asymmetrical)
	Comments	Criterion B	Criterion B
Surge voltage load (surge) EN 61000-4-5			
	Input	1 kV (Test Level 3 - symmetrical) 2 kV (Test Level 3 - asymmetrical)	3 kV (Test Level 4 - symmetrical) 6 kV (Test Level 4 - asymmetrical)
	Output	0.5 kV (Test Level 1 - symmetrical) 0.5 kV (Test Level 1 - asymmetrical)	1 kV (Test Level 2 - symmetrical) 2 kV (Test Level 3 - asymmetrical)
	Signal	1 kV (Test Level 2 - asymmetrical)	1 kV (Test Level 2 - asymmetrical)
	Comments	Criterion B	Criterion A
Conducted interference EN 61000-4-6			
	Input/Output/Signal	asymmetrical	asymmetrical
	Frequency range	0.15 MHz ... 80 MHz	0.15 MHz ... 80 MHz
	Voltage	10 V (Test Level 3)	10 V (Test Level 3)
	Comments	Criterion A	Criterion A
Power frequency magnetic field EN 61000-4-8			
		50 Hz , 60 Hz ( 30 A/m )	16.67 Hz , 50 Hz , 60 Hz ( 100 A/m 60 s )
		not required	50 Hz , 60 Hz ( 1 kA/m , 3 s )
		not required	0 Hz ( 300 A/m , DC, 60 s )
	Comments	Criterion A	Criterion A
<b>Key</b>			
Criterion A	Normal operating behavior within the specified limits.		
Criterion B	Temporary impairment to operational behavior that is corrected by the device itself.		

## 5 Symbols used

In this installation note symbols are used in order to call attention to notices and dangers.



This is the safety alert symbol. It is used to alert you to potential personal injury hazards. Obey all safety measures that follow this symbol to avoid possible personal injuries. This indicates a hazardous situation which, if not avoided, could result in death or serious injury.

There are different categories of personal injury that are indicated by a signal word.



**WARNING**  
This indicates a hazardous situation which, if not avoided, could result in death or serious injury.



**CAUTION**  
This indicates a hazardous situation which, if not avoided, could result in minor or moderate injury.

The following symbols are used to indicate potential damage, malfunctions, or more detailed sources of information.



**NOTE**  
Indication of a required action which if it is not performed may cause damage or malfunction to the device, hardware/software, or surrounding property.



This symbol and the accompanying text provide the reader with additional information or refer to detailed sources of information.



This symbol and the accompanying text provide additional information on the correct disposal of used batteries.



This symbol and the accompanying text provide additional information on recycling.



## 6 Safety regulations and installation notes



**WARNING: Danger to life by electric shock!**

- Only skilled persons may install, start up, and operate the device.
- For indoor use only.
- Never carry out work when voltage is present.
- Establish connection correctly and ensure protection against electric shock.
- Cover termination area after installation in order to avoid accidental contact with live parts (e. g., installation in control cabinet).
- This unit receives power from more than one source - disconnect the input power source and the energy storage to de-energize this unit before servicing.
- Keep flames, embers or sparks away from the module.
- When connecting the external batteries, observe the polarity and do not short circuit the pole terminals.
- Provide a switch/circuit breaker close to the device at the DC input, DC output and at the battery terminals, which are labeled as the disconnecting device for these devices.
- Do not disconnect the fuse and / or battery connection under hazardous location conditions.



**NOTE**

- The uninterruptible power supply is maintenance-free. Repairs may only be carried out by the manufacturer. The warranty no longer applies if the housing is opened.
- Improper use invalidates the device protection.
- The uninterruptible power supply may only be used for its intended use.
- Observe the national safety and accident prevention regulations.
- Assembly and electrical installation must correspond to the state of the art.
- The uninterruptible power supply is a built-in device. The protection class IP20 of the device is meant to be applied in a clean and dry environment.

- The device must be installed in a control cabinet that can be locked and only opened by specialist staff.
- Observe mechanical and thermal limits.
- Ensure sufficient convection. Housing can become hot. The minimum distance (above/below) is shown in the relevant figure.
- Use a current-limited source (QUINT POWER) or a suitable fuse at the DC input and a battery with a suitable fuse at the UPS battery connection. Mark the fuses as being disconnection devices.
- Ensure that the primary-side wiring and secondary-side wiring are the correct size and have sufficient fuse protection.
- Use copper cables for operating temperatures of >75 °C (ambient temperature <55 °C) >90 °C (ambient temperature <75 °C).
- You can find the connection parameters, such as the necessary stripping length for the wiring with and without ferrule, in the associated table.
- When connecting the external batteries, observe the polarity and do not short circuit the pole terminals.
- Protect the device against foreign bodies penetrating it, e.g., paper clips or metal parts.
- To reduce the risk of fire, replace fuses only with those that have the same type and rating. Relevant fuses can be found in the accessories in the ordering data.
- To reduce the risk of fire, connect only to a circuit provided with the following maximum branch circuit overcurrent protection in accordance with the National Electrical Code, ANSI/NFPA 70.



The switching outputs are active outputs according to SELV. These may only be operated on permitted SELV circuits.

The permanent output power  $P_N$  is limited at an ambient temperature of 60 °C. Observe all the maximum output powers for the respective operating conditions.

## 7 Design

### 7.1 Rating plate

In accordance with the German Product Safety Law (ProdSG) it is only permissible to make such products available on the market if they meet certain safety standards. It must be ensured at all times that users are not exposed to hazards.

In accordance with ProdSG, every device must therefore be fitted with a rating plate. All relevant information on the safe use of the device must also be included.

### Key

No.	Designation
1	QR code as web link to the device documentation
2	Identification of the provider
3	Device connection data
4	Device approvals
5	Production site of the PHOENIX CONTACT Group
6	Bar code and serial number for device identification
7	Date of manufacture
8	Designation of device revision
9	Designation of product-related device documentation
10	Bar code and MAC address for the unambiguous identification of the device in the network Only applicable to device versions: - QUINT4-UPS/24DC/24DC/xx/PN - QUINT4-UPS/24DC/24DC/xx/EIP

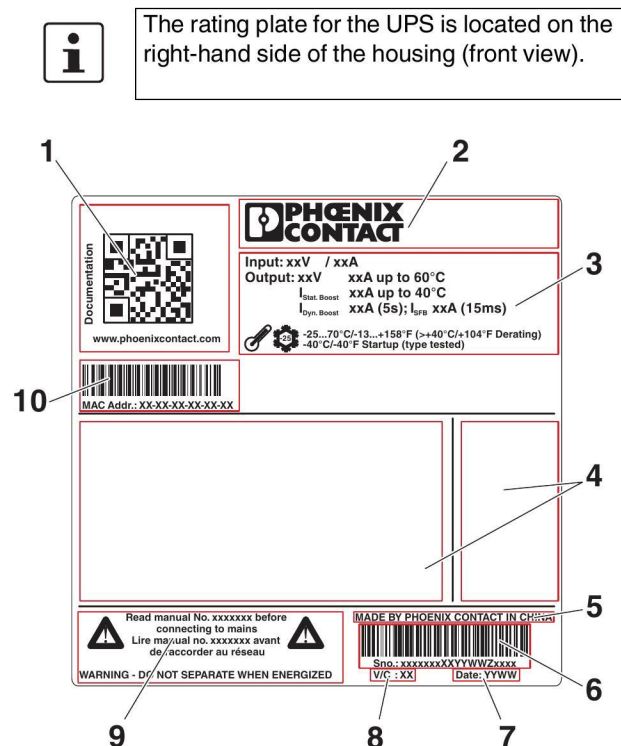

Figure 1 Rating plate information

7.2 Device connections and functional elements

Device connections are labeled with connection tags to ensure clear and definitive identification.

The connection tags are split into the following connection levels:

Connection level	Description
1.x	Input
2.x	Output
3.x	Signals
4.x	Energy storage (battery)
Xx	Communication interface Only applicable to device versions: - QUINT4-UPS/24DC/24DC/xx/USB - QUINT4-UPS/24DC/24DC/xx/PN - QUINT4-UPS/24DC/24DC/xx/EIP - QUINT4-UPS/24DC/24DC/xx/EC

Key

No.	Designation	Connection labeling
1	Connection terminal blocks input voltage: Input DC +/-	1.1, 1.2
2	Connection terminal blocks output voltage: Output DC +/-	2.1, 2.2
3	Accommodation for cable binders	--
4	Signaling connection terminal blocks	3.1 ... 3.9
5	LED status indicator for battery charge state	--
6	Universal DIN rail adapter (rear of housing)	--
7	Rotary selector switch for setting the buffer time $t_{max}$ [min]	--
8	Service key for battery replacement	--
9	Connection terminal blocks battery: +/-signal	4.1 ... 4.3
10	Communication interface (device underside)	X1 (X2)
11	Factory-set programming interface (device underside) 1x 8-pole or 2x 8-pole	--
12	QR code web link	--
13	LED status indicators for data traffic Valid only for the following device versions: - QUINT4-UPS/24DC/24DC/xx/PN - QUINT4-UPS/24DC/24DC/xx/EIP - QUINT4-UPS/24DC/24DC/xx/EC	--
14	LED status indicators for general device status	--

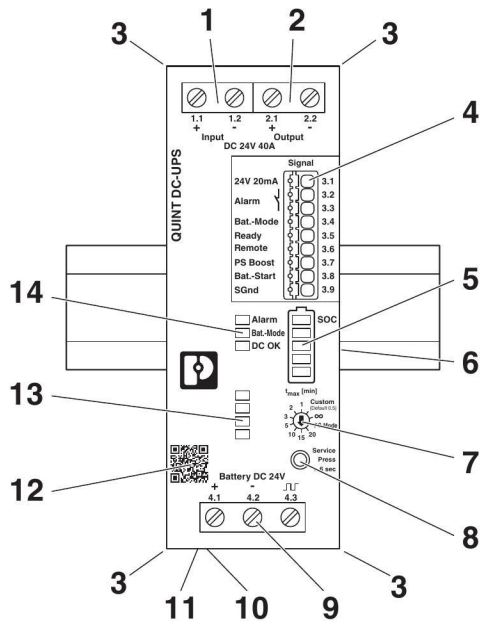

Figure 2 Location of functional elements and device connections

7.3 Block diagram

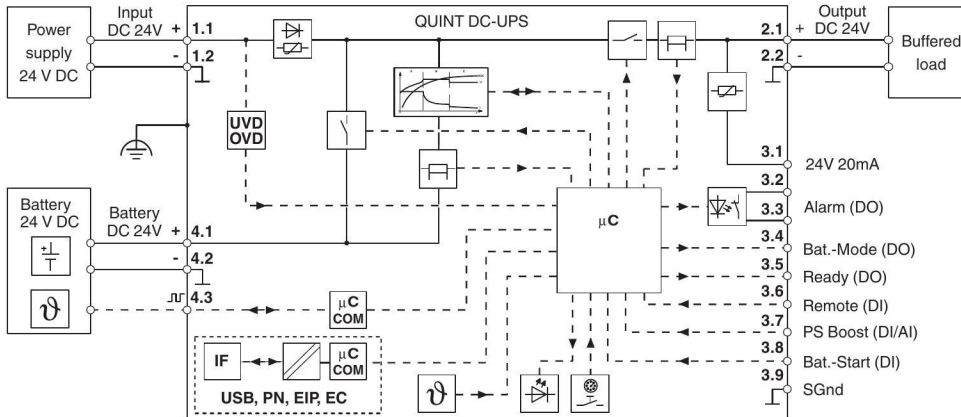

Figure 3 Block diagram

Key

Symbol	Designation - main elements
	Microcontroller
	Communication controller
	Battery charger
	Battery
	Communication interface Only applies to device versions: - QUINT4-UPS/24DC/24DC/xx/USB - QUINT4-UPS/24DC/24DC/xx/PN - QUINT4-UPS/24DC/24DC/xx/EIP - QUINT4-UPS/24DC/24DC/xx/EC

Symbol	Designation - auxiliary elements
	Switch (MOSFET)
	Floating switch
	Decoupling and soft start
	Current limitation
	Electrical isolation

Symbol	Designation - sensors/actuators
	Undervoltage and surge voltage detection
	Current sensor (shunt)
	Temperature sensor
	Rotary selector switches and buttons (control panel)
	Status LEDs

7.4 Device dimensions

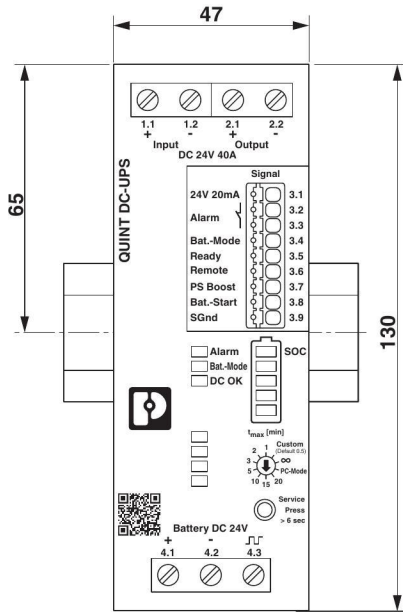

Figure 4 Device dimensions (dimensions in mm)

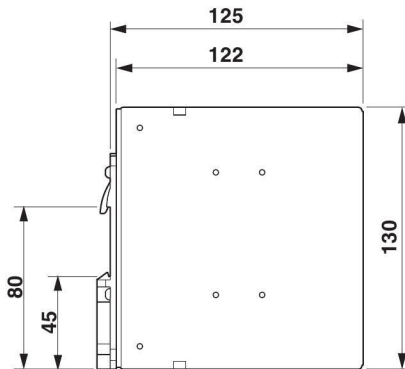

Figure 5 Device dimensions (dimensions in mm)



## 8 Mounting/remove

The fanless convection-cooled UPS can be snapped onto 35 mm DIN rails with a top hat profile (TH 35-7.5 / TH 35-15) in accordance with EN 60715.

### 8.1 Convection

To ensure sufficient convection, maintain an adequate minimum clearance between the UPS and above/below the installed devices. The required minimum clearances are dependent on the system load during normal operation. Information on required minimum clearances is provided in the "Restricted areas" section.

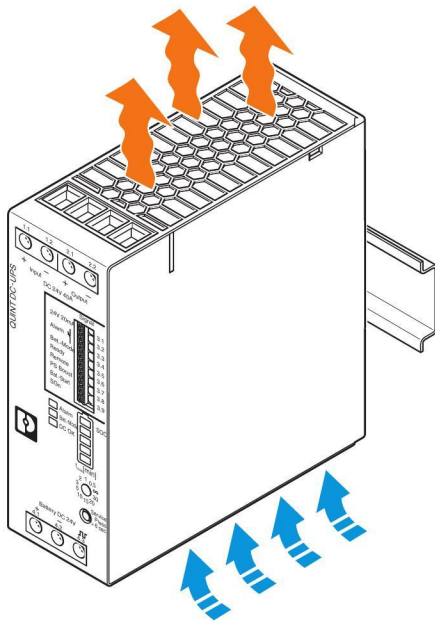

Figure 6 Schematic diagram of the convection cooling

### 8.2 Mounting position (Derating)

The specified technical data for the UPS is designed for operation in the normal mounting position. Any different technical data based on other mounting positions is labeled accordingly.

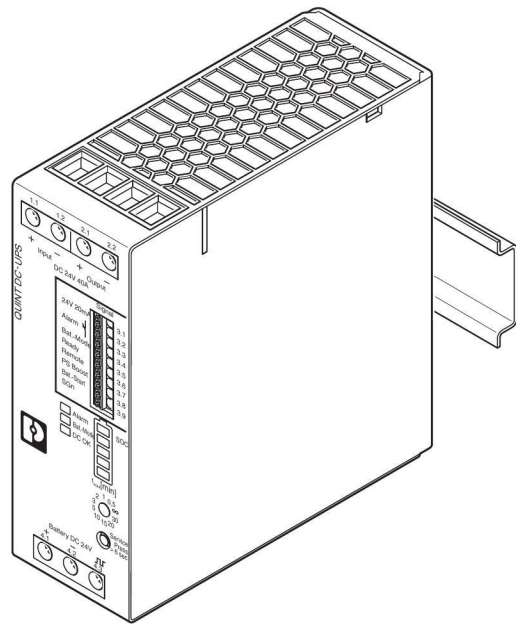

Figure 7 UPS mounted in normal mounting position

### 8.3 Installation height

The UPS can be operated at an installation height of up to 2000 m without any limitations. Different data applies for installation locations above 2000 m due to the differing air pressure and the reduced convection cooling associated with this (see technical data section). The data provided is based on the results of pressure chamber testing performed by an accredited test laboratory.

8.4 Keep-out areas

Distance to active or passive devices	Spacing [mm]		
	a	b	c
Active/passive $P_{Out} \leq 50\%$	40	20	0
Passive $P_{Out} \geq 50\%$			
Active $P_{Out} \geq 50\%$	50	50	5

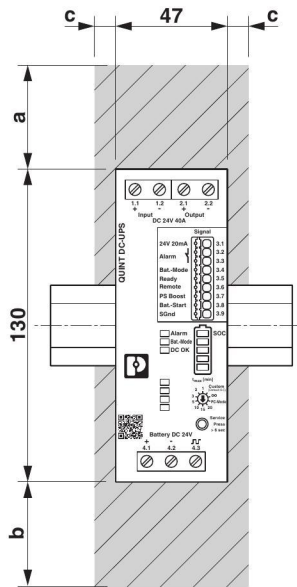

Figure 8 Device dimensions and minimum keep-out areas (in mm)

8.5 Mounting the UPS

Proceed as follows to mount the UPS:

1. In the normal mounting position, the UPS is mounted on the DIN rail from above. Make sure that the universal DIN rail adapter is in the correct position behind the DIN rail (A).
2. Then press the UPS down until the universal DIN rail adapter audibly latches into place (B).
3. Check that the UPS is securely attached to the DIN rail.

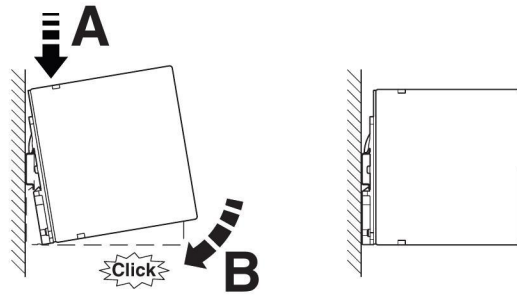

Figure 9 Snapping the uninterruptible power supply onto the DIN rail



If you use a QUINT UPS with a communication interface, the DIN rail on which the UPS is mounted must also be connected to the PE potential of the control cabinet via a separate FE terminal (functional ground).  
When installed on the DIN rail, the functional ground of the QUINT UPS is directly secured via the DIN rail adapter.

### 8.6 Removing the UPS

Proceed as follows to remove the UPS:

1. Take a suitable screwdriver and insert this into the lock hole on the universal DIN rail adapter (A).
2. Release the lock by lifting the screwdriver (B).
3. Carefully swivel the UPS forward (C) so that the interlock slides back into the starting position.
4. Then lift the UPS from the DIN rail (D).

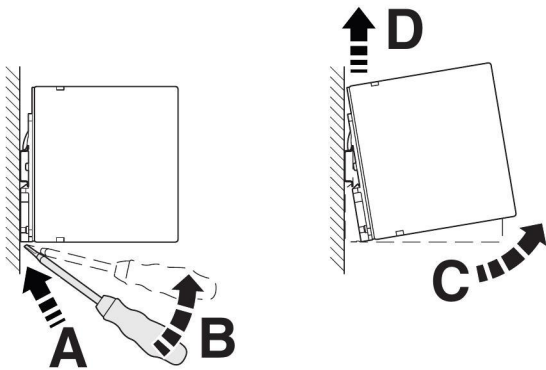

Figure 10 Removing the uninterruptible power supply from the DIN rail

### 8.7 Retrofitting the universal DIN rail adapter

For installation in horizontal terminal boxes, it is possible to mount the UPS at a 90° angle to the DIN rail.

No additional mounting material is required.



Use the Torx screws provided to attach the universal DIN rail adapter to the uninterruptible power supply.

### 8.7.1 Disassembling the universal DIN rail adapter

Proceed as follows to disassemble the universal DIN rail adapter that comes pre-mounted:

1. Remove the screws for the universal DIN rail adapter using a suitable screwdriver (Torx 10).
2. Remove the universal DIN rail adapter from the rear of the uninterruptible power supply.

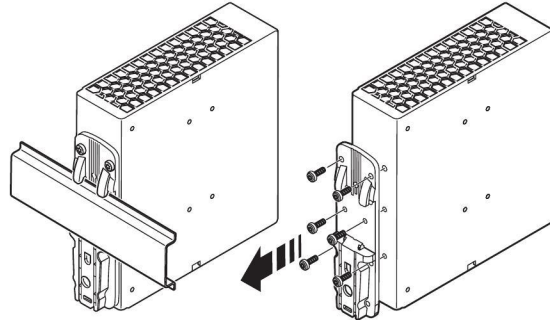

Figure 11 Disassembling the universal DIN rail adapter

### 8.7.2 Mounting the universal DIN rail adapter

To mount the universal DIN rail adapter on the left side of the device, proceed as follows:

1. Position the universal DIN rail adapter on the left side of the housing so that the mounting holes are congruent with the hole pattern for the mounting holes.
2. Insert the Torx screws that were removed earlier into the appropriate hole pattern on the universal DIN rail adapter so that the necessary drill holes on the power supply can be accessed.
3. Screw the universal DIN rail adapter onto the power supply.



The maximum tightening torque of the Torx screw (Torx® T10) is 0.7 Nm.

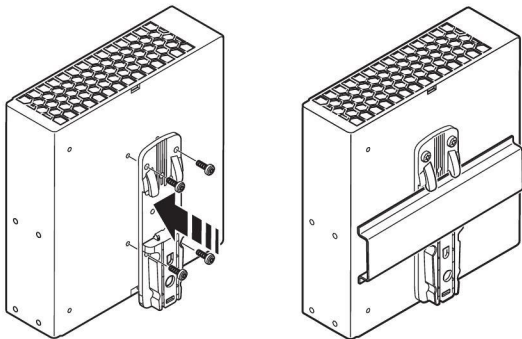

Figure 12 Mounting the universal DIN rail adapter

### 8.8 Retrofitting the universal wall adapter

The UWA 182/52 (Order No. 2938235) or UWA 130 (Order No. 2901664) universal wall adapter is used to attach the UPS directly to the mounting surface.

The use of universal wall adapters is recommended for extreme ambient conditions, e. g., strong vibrations. An extremely high level of mechanical stability is ensured thanks to the tight screw connection between the UPS and universal wall adapter or the actual mounting surface.



The uninterruptible power supply is attached to the UWA 182 or UWA 130 universal wall adapter by means of the Torx screws for the universal DIN rail adapter.

### 8.8.1 Mounting the UWA 182/52 universal wall adapter

Proceed as follows to disassemble the universal DIN rail adapter that comes pre-mounted:

1. Remove the screws for the universal DIN rail adapter using a suitable screwdriver (Torx 10).
2. Remove the universal DIN rail adapter from the rear of the uninterruptible power supply.
3. Position the universal wall adapter in such a way that the keyholes or oval tapers face up. The mounting surface for the uninterruptible power supply is the raised section of the universal wall adapter.
4. Place the UPS on the universal wall adapter in the normal mounting position (input and output voltage connection terminal blocks at top).
5. Insert the Torx screws into the appropriate hole pattern on the universal wall adapter so that the necessary mounting holes of the UPS can be accessed.
6. Screw the universal wall adapter onto the UPS.

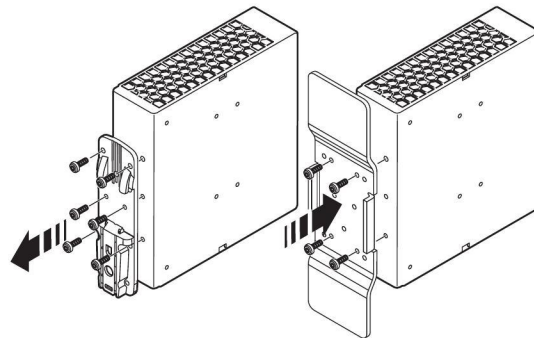

Figure 13 Mounting the UWA 182/52 universal wall adapter



If you use a QUINT UPS with a communication interface, universal wall adapter UWA 182/50 on which the UPS is mounted must also be connected to the PE potential of the control cabinet via a separate FE terminal (functional ground).

The electric connection of the functional ground can, for example, be implemented via a mounting screw for universal wall adapter UWA 182/50. Ensure the electrical conductivity of painted surfaces, if required.



The maximum tightening torque of the Torx screw (Torx® T10) is 0.7 Nm.





Make sure you use suitable mounting material when attaching to the mounting surface.

### 8.8.2 Mounting the UWA 130 2-piece universal wall adapter

Proceed as follows to disassemble the universal DIN rail adapter that comes pre-mounted:

1. Remove the screws for the universal DIN rail adapter using a suitable screwdriver (Torx 10).
2. Remove the universal DIN rail adapter from the rear of the uninterruptible power supply.
3. Position the universal wall adapter. The mounting surface for the UPS is the raised section of the universal wall adapter.
4. Place the UPS on the universal wall adapter in the normal mounting position (input and output voltage connection terminal blocks at top).
5. Insert the Torx screws into the appropriate hole pattern on the universal wall adapter so that the necessary mounting holes of the UPS can be accessed.
6. Screw the two-piece universal wall adapter onto the UPS.

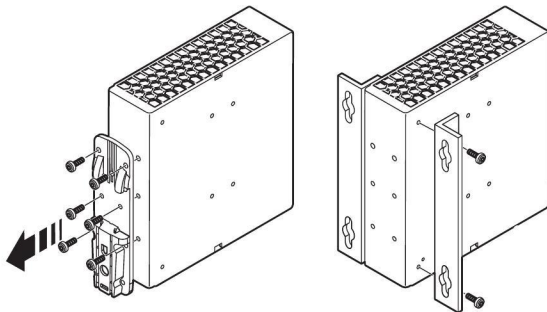

Figure 14 Mounting the UWA 130 universal wall adapter



If you use a QUINT UPS with a communication interface, universal wall adapter UWA 130 on which the UPS is mounted must also be connected to the PE potential of the control cabinet via a separate FE terminal (functional ground).

The electric connection of the functional ground can, for example, be implemented via a mounting screw for universal wall adapter UWA 130. Ensure the electrical conductivity of painted surfaces, if required.

## 9 Device connection terminal blocks / device interfaces

The DC input and output terminal blocks and the battery terminals on the front of the uninterruptible power supply feature screw connection technology. The signal level wiring is connected via tool-free Push-in connection technology.



For the necessary connection parameters for the screw- or Push-in connection terminal blocks, refer to the technical data section.

Depending on the UPS version used, these are equipped with a USB or two RJ45 interfaces for communication purposes.



Additional information is provided in the "Communication interface" section.



### 9.1 DC input terminal

The UPS is primarily supplied by a current-limiting source (QUINT PS) with a 24 V DC voltage. The UPS is connected on the primary side via the INPUT DC connection terminal blocks (connection level 1x input).

**i** To dimension the power supply correctly, you must first determine the total current consumption of the system being supplied. The total current consumption is made up of the maximum load current and the maximum battery charging current.

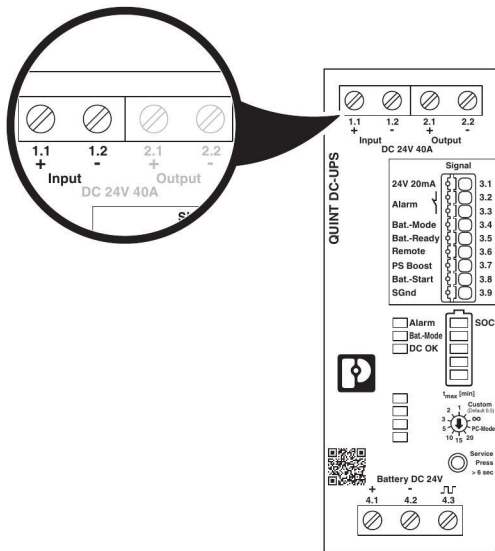
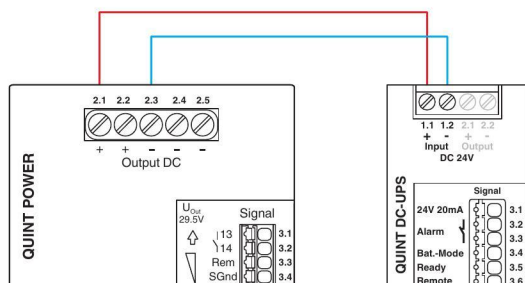

Figure 15 Position of DC input terminals

### Wiring principle for DC input terminals



### 9.2 DC output terminal blocks (buffered load)

In the event of an incident, connect the buffered load to the output DC connection terminal blocks (connection level 2x outputs). In the event of a malfunction of the upstream power supply, the load is supplied with the energy stored in the battery.

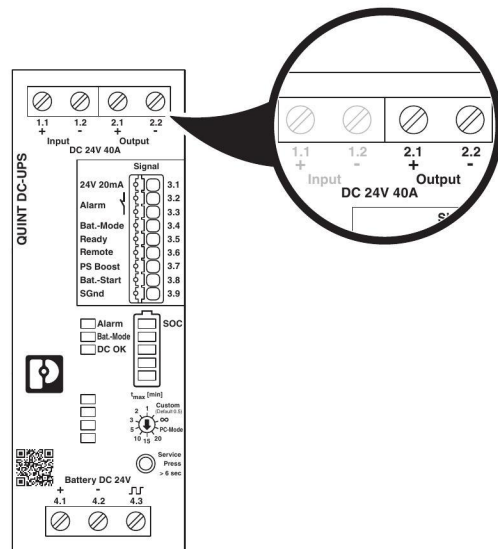
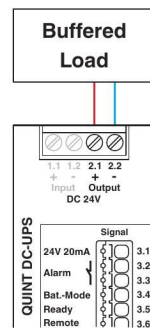

Figure 16 Position of DC output terminals

### Wiring principle for DC output terminals



### 9.3 Signal terminal blocks

The connection terminal block signals (connection level 3x signals) are divided into the following signals for controlling and signaling the operating states of the UPS.

#### 9.3.1 +24 V DC (SGnd reference potential)

Continuous +24 V signal voltage (3.1), e. g. to supply the floating switch contact (3.2, 3.3). The signal voltage is available during mains and battery-powered operation.



Observe the maximum current carrying capacity of the signal output: 20 mA  
The internal electronic fuse protects the signal output against damage. The signal output is activated again once the malfunction has been eliminated.

#### 9.3.2 Floating switch contact

- Alarm (3.2, 3.3), default setting. When supplied through the +24 V signal voltage, this switch contact is used as a digital output (DO).

#### 9.3.3 Digital outputs (DO)

- Bat.-Mode (3.4)
- Ready (3.5)

#### 9.3.4 Digital inputs (DI)

- Remote (3.6)
- Bat.-Start (3.8), cannot be configured

#### 9.3.5 Digital/analog input (DI/AI)

- PS Boost (3.7)

#### 9.3.6 SGnd (reference potential)

- The signal ground SGnd (3.9) is the reference potential for the signal voltage 24 V DC, 20 mA (3.1). SGnd is also the reference potential for signal outputs (3.4, 3.5) and signal inputs (3.6, ..., 3.8).

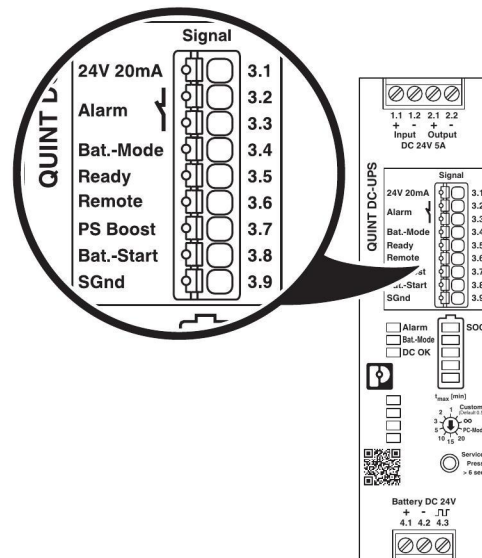

Figure 17 Location of signal terminal blocks

#### Wiring principle of the signal terminal blocks

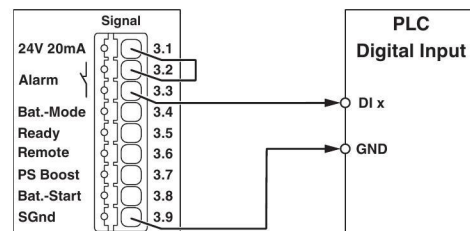

Figure 18 Wiring principle floating switching output

### 9.4 Battery terminals

Connect the battery, required in the event of an incident, to the battery terminals (connection level 4x energy storage (battery)). In the event of a malfunction of the upstream power supply, the load is continuously supplied with the energy stored in the battery.

Phoenix Contact batteries from the UPS-BAT series have additional connection terminal blocks. The signal terminal is used to communicate with the uninterruptible power supply. Communication with the uninterruptible power supply thus ensures full support of the battery management system (BMS).

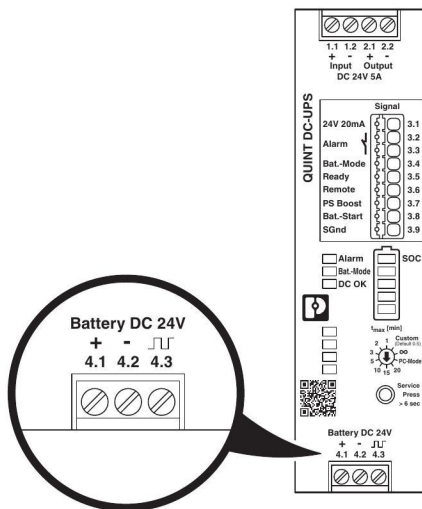
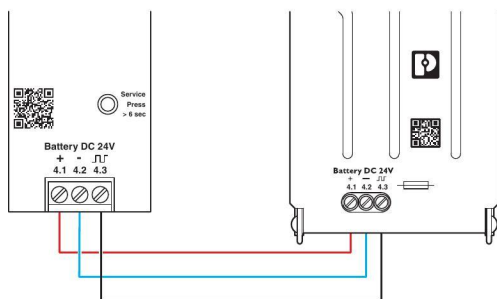

Figure 19 Location of battery terminals

### Wiring principle for battery terminals



### 9.5 Communication interface

Depending on the UPS version used, it is designed to communicate with one or more communication interfaces. The USB communication interface or RJ45 communication interfaces are located on the underside of the UPS.

#### 9.5.1 USB communication interface

The USB communication interface has a MINI USB type B socket connection method. The connection level is marked X1. To ensure the safe connection of the USB connector during industrial applications, the MINI USB type B socket is fitted with two threaded bushes.

The following UPS version is equipped with a USB communication interface:

- QUINT4-UPS/24DC/24DC/xx/USB

### Contact assignment

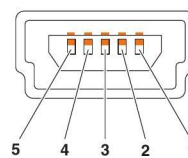

### Key

Pin	Name	Designation
1	VCC	+5 V DC
2	D-	Data -
3	D+	Data +
4	ID	none
5	GND	Ground

**Location of the USB interface**

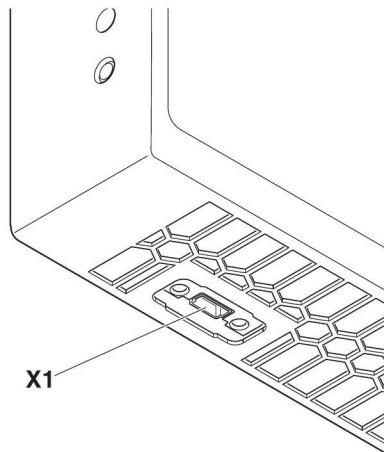
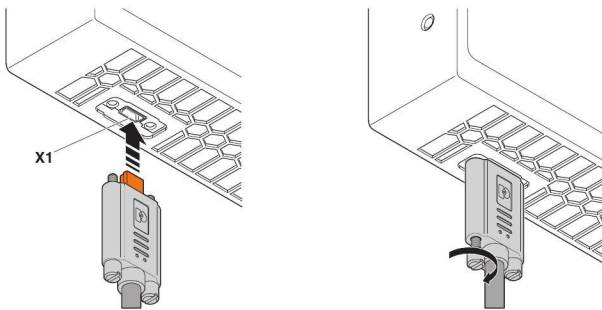

Figure 20 USB interface on the bottom of the device



**9.5.2 RJ45 communication interfaces**

The RJ45 communication interfaces meet Ethernet standard IEEE 802.3 and are assigned to connection level X1 or X2. The contact assignment for the RJ45 connectors is in accordance with the 10BASE-T- or 100BASE-TX standard.

The snap-in hook on the RJ45 connector secures it from slipping out of the RJ45 socket.

**Contact assignment**

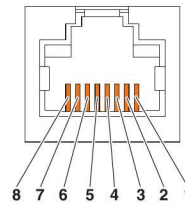

**Key**

Pin	Name	Designation
1	TxD+	Transmit data +
2	TxD-	Send data -
3	RxD+	Receive data +
4	Reserved	none
5		
6	RxD-	Receive data -
7	Reserved	none
8		

**Location of the RJ45 interface**

The following UPS version is equipped with two RJ45 communication interfaces:

- QUINT4-UPS/24DC/24DC/xx/PN
- QUINT4-UPS/24DC/24DC/xx/EIP
- QUINT4-UPS/24DC/24DC/xx/EC

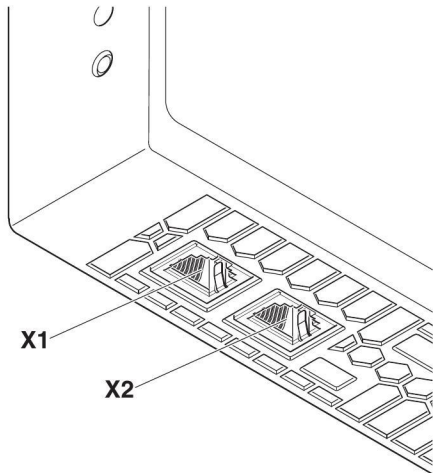
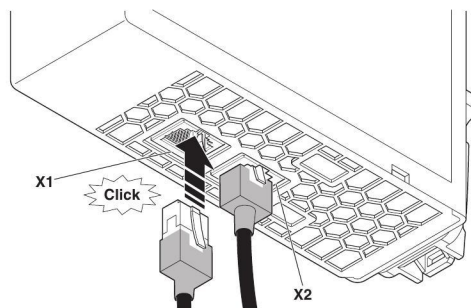

Figure 21 RJ45 interfaces on the bottom of the device



**9.6 Securing the connection wiring**

Two receptacles for the bundled attachment of the connection wiring are integrated in the left and right housing panel. Use cable binders to secure the connection wiring (optional PKB 140X3,6 - Order No. 1005460).

Proceed as follows to secure the connection wiring:

- Connect the uninterruptible power supply with sufficient connection reserve (input terminal blocks, output terminal blocks, signal terminal blocks, battery terminals)
- Bundle and set up the connection wiring so that the cooling grilles on the top and bottom of the housing are covered as little as possible.
- Thread the cable binders into the necessary receptacles for the cable binders.

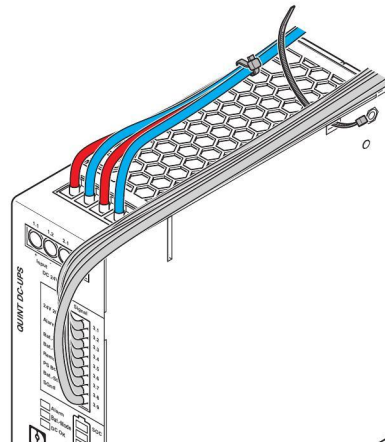

Figure 22 Lay and align connection wiring

- Secure the connection wiring with the cable binders. Make sure that the connection wiring is attached safely and securely without damaging the connection wiring.

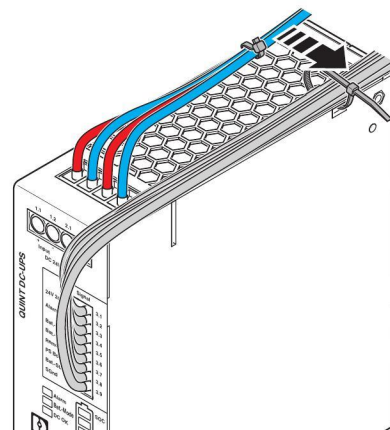

Figure 23 Secure connection wiring with cable binder



- Shorten the excess length of the cable binder ends.
- Then check again that the connection wiring is properly secured.

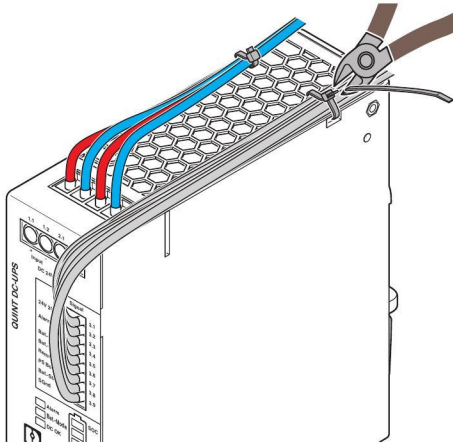

Figure 24 Shorten protruding ends of the cable binder



**NOTE:** Mechanical damage to the connection wiring caused by friction

In extreme ambient conditions, e.g., strong vibrations, protect the connection wiring against mechanical damage using additional insulation material. The additional insulation material for protecting the connection wiring is limited to the area where the cable binders are attached.

## 10 Function elements

The basic operation of the UPS is implemented via a multi-level rotary selector switch and service button.

The rotary selector switch is generally used to set how long the load should be supplied with energy in the event of an incident.

The axis of the rotary selector switch has a groove that is marked with an arrow. Use a suitable screwdriver (SZS 0,4X2,5 VDE, 1205037) to move the head of the arrow to the required maximum time.



Depending on the customer's parameterization of the UPS, the rotary selector switch and service button may be disabled within the software.

It is enabled or disabled within the software using the UPS-CONF configuration software (Order No. 2320403).

For additional information, please refer to the user manual for the UPS-CONF configuration software.

The device status of the UPS or overall system is indicated via status LEDs.

If the UPS also has an Ethernet- or Profinet-based communication interface (2x RJ45 interfaces), four additional status LEDs are provided for the communication.

### 10.1 Operating element – rotary selector switch



The rotational direction of the rotary selector switch is not specified. The rotary selector switch is also designed without a limit stop. The rotary selector switch can thus be overwound accidentally without being damaged.



If the UPS has one communication interface, the range of functions that you can set on the rotary selector switch will differ.

### 10.1.1 UPS without communication interface

In the event of an incident, the behavior of the UPS can be set via the 10-stage rotary selector switch  $t_{max}$  [min] on the front of the device. Depending on the application in your system, select between time-limited operation or another function.

For a time-limited load supply, select the required maximum time via the rotary selector switch position. The load is supplied with energy up to the maximum preselected time. The UPS is then shut down.

In the  $\infty$  rotary selector switch position, the load is supplied until the battery's deep discharge protection comes into effect. The UPS is then shut down.

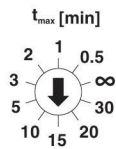

Figure 25 Rotary selector switch (UPS without communication interface)

### 10.1.2 UPS with communication interface

In principle, preselection of the buffer time is identical to the UPS without communication. The additional PC mode function is only available on a UPS with an integrated communication interface.

When using the PC mode function, you must choose between a UPS with a USB or RJ45 connection. The use of your application also varies depending on the communication interface used.

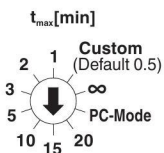

Figure 26 Rotary selector switch (UPS with communication interface)

### Communication via the USB interface

In this case of point-to-point coupling (modbus/RTU protocol), the connected PC continues to operate in the event of a mains failure.

Battery operation guarantees availability until all of the data from the PC buffer has been saved. The PC then performs a controlled shutdown.

The PC is restarted when the mains voltage is restored.



The optional USB connection cable (MINI SCREW USB DATA CABLE, Order No. 2908217) is required for a controlled shutdown in PC mode.

### Communication via the RJ45 interface

Depending on the communication protocol (PROFINET, EtherNet/IP™ or EtherCAT®) used, the UPS is integrated in a corresponding industrial network.

Various fieldbus topologies, such as bus, ring, and star topologies, are supported.

In these cases, the UPS behaves like a network device that communicates with other network devices in PC mode. This additional network device is either a directly connected control PC (point-to-point coupling) or a higher-level controller (part of an industrial network).

In the event of a supply voltage failure, the UPS switches over to battery operation without any interruptions. The connected load continues to be supplied. Depending on the existing programming, the network device simultaneously takes over control tasks to manage the shutdown of system components or the system, for example.



Only use approved communication cables from Phoenix Contact in accordance with the implemented communication protocol.

### 10.2 Operating element – service button

Use the service button to switch between the different services modes of the UPS. Certain prerequisites may be required depending on the selected service mode.

The following service modes are available:

1. Work on the battery terminals
2. Battery replacement
3. Load default settings



Figure 27 Service button



Additional information on the communication interface is provided in the "Interfaces" section.

### 10.3 Display elements

Regardless of the device-type that is used, the front display elements of the UPS are split into two or three functional LED display units.

#### 10.3.1 LED status indicators for device status

All of the devices have three LED status indicators. The Alarm, Bat.-Mode, DC OK LED status indicators inform you about the current device status of the UPS.

- Alarm
- Bat.-Mode
- DC OK

Figure 28 LED status indicators for device status

#### 10.3.2 LED status indicators for charging status

The 5-stage state of charge (SOC) LED bar graph display informs you about the current charging state of the connected battery. The direction of the LED bar graph indicates whether the battery is being charged or discharged. This function can only be used in combination with Phoenix Contact batteries with IQ Technology.

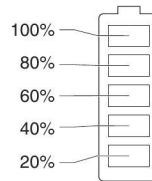

Figure 29 LED status indicators for charging status

#### 10.3.3 LED status indicators for data traffic

Devices with an Ethernet- or Profinet-based communication interface (2x RJ45 interfaces) are also equipped with four LED status indicators for data communication.



Figure 30 LED status indicators for PROFINET, EtherNet/IP™, EtherCAT®



Additional information on the communication interface is provided in the "Interfaces" section.



## 11 System configuration



The technical characteristics indicated relate to the factory setting of the standard device. Devices with customer-specific parameterizations may have different technical characteristics.



If devices also have a USB or RJ45 communication interface, additional device-specific information is indicated separately at the relevant points.

The modular system configuration and different performance classes of an uninterruptible power supply ensure that a suitable solution can be found for every application.

Different performance classes are available to guarantee optimum adjustment and assurance of the system availability.

The standard configuration of the modular system consists of the following components. The primary power supply supplying the load, the uninterruptable DC power supply (switching unit) with intelligent battery management system, and the energy storage unit (battery) to continue supplying the load in the event of a mains failure.

The switching units and batteries with IQ Technology from Phoenix Contact are exceptionally well suited for preventative function monitoring, thanks to the following features:

- The intelligent battery management system (BMS) automatically recognizes the connected Phoenix Contact battery type. This ensures that optimum charging characteristics are provided for every battery type, which is reflected in the service life of the battery, amongst other things.
- The intelligent battery charging control adapts the charging current. The fastest possible recharging of the batteries and availability of the system is guaranteed in the event of an incident.
- You are informed of the current charging state (SOC - state of charge) and thus the remaining runtime of the battery under constant ambient conditions.
- The state of charge (SOC) informs you of the remaining runtime of the battery in the event of a mains failure.
- The state of health (SOH) warns you about a possible unexpected failure of the battery at an early stage.



Depending on the required supply duration and size of the load, you can use up to five batteries of the same type and load to maximize the buffer time.

### 11.1 System prerequisites for the use of Phoenix Contact batteries



The UPS recognizes and supports the following Phoenix Contact batteries. Observe the minimum required V/C level (V/C: xx) of the battery here. The actual V/C level of the battery is to be found on the side printing on the battery housing.  
Up to five batteries may be connected in parallel to increase the total capacity, depending on the type of batteries used.

The minimum required V/C level and the permissible total number of batteries connected in parallel are shown in the table.

Product designation	Order No.	From V/C level	Σ of the batteries (without additional loader)
UPS-BAT/VRLA/24DC/1.3AH	2320296	08	5
UPS-BAT/VRLA/24DC/3.4AH	2320306	08	5
UPS-BAT/VRLA/24DC/7.2AH	2320319	08	5
UPS-BAT/VRLA/24DC/12AH	2320322	08	3
UPS-BAT/VRLA/24DC/38AH	2320335	06	1
UPS-BAT/VRLA-WTR/24DC/13AH	2320416	06	3
UPS-BAT/VRLA-WTR/24DC/26AH	2320429	06	1
UPS-BAT/LHON/24DC/120WH	2320351	10	5
UPS-BAT/LHON/24DC/924WH	2908232	01	1

## 12 Operating states and basic functions



This section describes the basic functions and operating states for the UPS version without a communication interface. In UPS versions with a communication interface, the basic functions and operating states correspond to the factory settings.

UPS systems are used to ensure that all critical loads continue to be supplied in the event of malfunctions such as mains voltage interruptions or failures. In the event of an incident, the UPS switches to battery operation without interruption so that connected DC consumers continue to be continuously supplied. UPS mode can assume various operating states.

Basic information on the operating states is provided in the status diagram. Detailed information is provided in the following section.

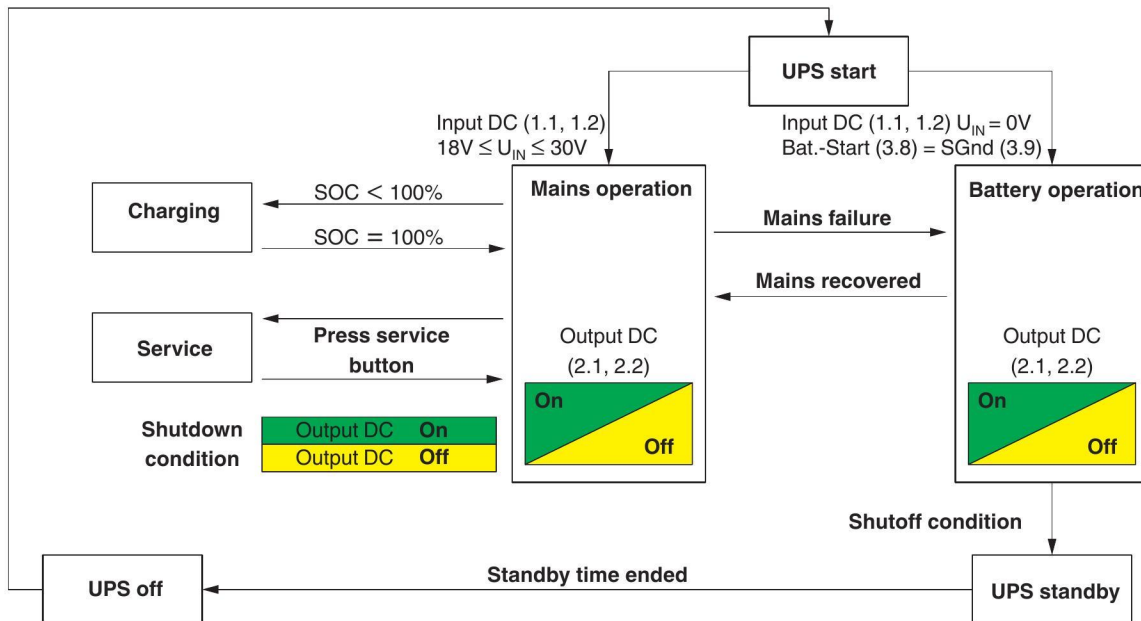

Figure 31 State diagram



### 12.1 Initialization of UPS startup

Initialization is implemented if the prerequisites for UPS startup are met. The LED test is completed during initialization. During this process, each LED is switched on and off again once. After initialization has been completed, the UPS is ready for operation. The connected DC load is supplied with energy.

#### 12.1.1 Input supply

The UPS will start if the input voltage is within the defined input voltage range.

#### 12.1.2 Cold restart (battery start)

The cold restart function offers the option of starting the UPS without a supply voltage on the input side. Energy from the connected battery is used to supply the UPS as well as the load. You therefore also have the option of operating the UPS as part of a mobile installation.

If you would like to use the cold restart function, briefly connect the two Bat.-Start (3.8) and SGnd (3.9) signal terminal blocks. The initialization of the UPS, including the LED test, then begins.

Following initialization, the UPS switches to the battery operating state. The output voltage provided at the load matches the battery voltage. The maximum duration of the autonomous supply for the load depends on the charging state of the battery.

The following events will terminate autonomous operation of the UPS:

- Supply voltage is available on the input side.
- Remote (3.6) and SGnd (3.9) signal terminal blocks are briefly connected.
- A shutdown condition, such as the battery's deep discharge protection, is triggered.



The connected PC is shut down immediately, if the PC mode setting is preselected on the rotary selector switch for setting the buffer time.

### 12.1.3 Function of the service button (load default setting)

If you have to reset the UPS to the default settings, proceed as follows:

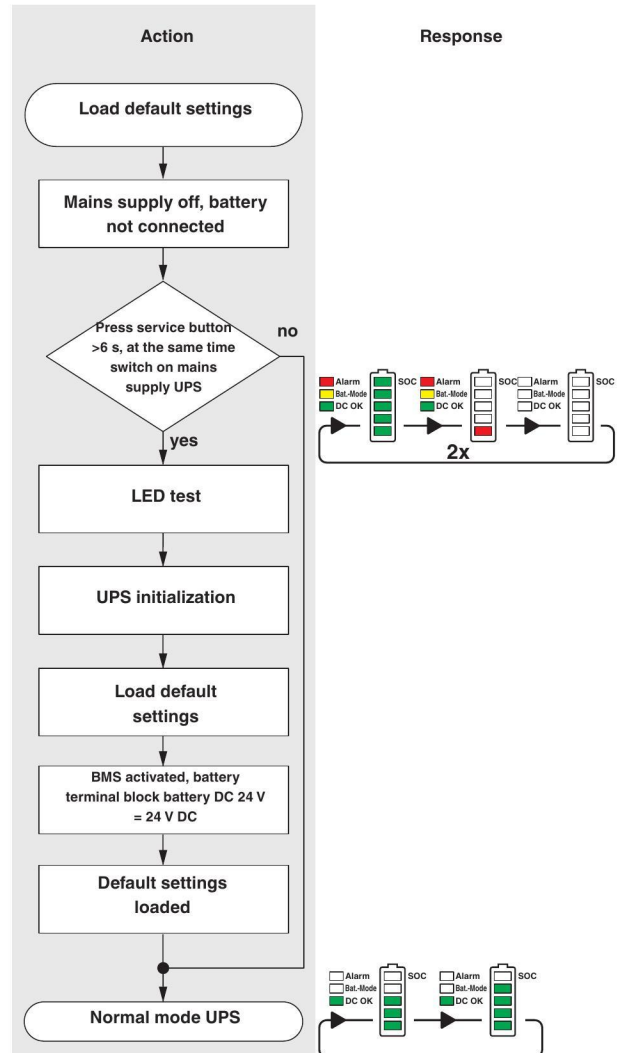

### 12.1.4 Signaling

Event	LED			Signal			LED
	Alarm	Bat.-Mode	DC OK	Alarm	Bat.-Mode	Ready	SOC bar graph
	red	yellow	green				
Input voltage is outside the defined input voltage range	0	0	0	L	L	L	0
Input voltage is within the defined input voltage range	LED test	LED test	LED test	H	L	L	LED test
Cold restart, SOC unknown	1	1	0	L	H	L	Top to bottom
Default settings loaded successfully	B	B	B	H	L	L	B

0 = Off, 1 = On  
 H = High, L = Low  
 B = Flashing

### 12.2 Mains operation

A stable supply voltage is available during mains operation, all of the functional elements of the UPS are active and ready for operation at any time. A corresponding alarm message is displayed if the UPS detects any irregularities that could cause a malfunction.

#### 12.2.1 Output/supply of the load

The upstream supply source at the input terminals (1.1, 1.2) supplies the DC load in addition to the internal charging unit of the UPS. The load connected to the DC output (2.1, 2.2) is always supplied with identical supply characteristics to the supply source. Optimized charging of the connected batteries (4.1, ..., 4.3) is controlled via the charging unit of the UPS.

#### 12.2.2 Remote

You can control the operational behavior of the UPS via the remote function. Use of the digital remote input (3.6) always requires the state to change at the signal input. If the remote input is not switched externally or there is a high input resistance, battery operation is automatically activated in the event of a mains failure.

However, if the remote input (3.6) is connected to the SGnd (3.9) signal terminal, battery operation is deactivated in the event of a mains failure. The load connected to the DC output (2.1, 2.2) is not supplied. The green flashing DC OK LED indicates that the remote function is activated.

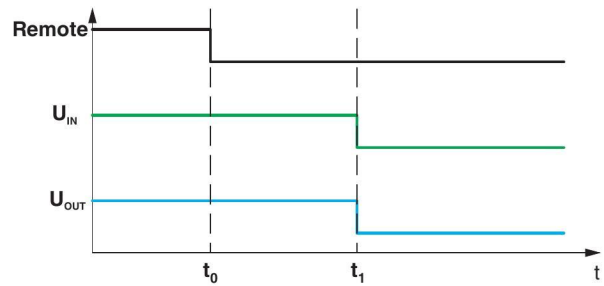

Time	Event
t <sub>0</sub>	The remote signal is set in mains operation.
t <sub>1</sub>	No input voltage, output is switched off.



Application example: main switch for shutdown (default)  
 By default, battery operation is permanently enabled for universal UPS applications. Connect the remote input (3.6) to the SGnd potential (3.9) via an auxiliary contact on the main switch (N/C contact).  
 If the system is now switched off via the main switch, the UPS is also fully deactivated.

### 12.2.3 Function of the service button (service mode)

If you need to complete any maintenance work on the system, it may be sensible to also place the UPS in service mode. Switch the UPS to service mode during continuous mains operation, by pressing and holding the service button for >6 seconds. The associated alarm state is activated when the unit is switched over to service mode.

The internal charging unit is deactivated and the battery DC 24 V (4.1, ..., 4.3) connection terminal blocks are disconnected in service mode.

If the UPS is operated in service mode during mains operation and the mains supply malfunctions, the UPS will not switch to battery operation.



**WARNING: Risk of injury caused by uncontrolled startup of the load**  
 You must also remove the battery fuses to prevent the battery-powered supply of the load in the event of a mains failure during service mode.

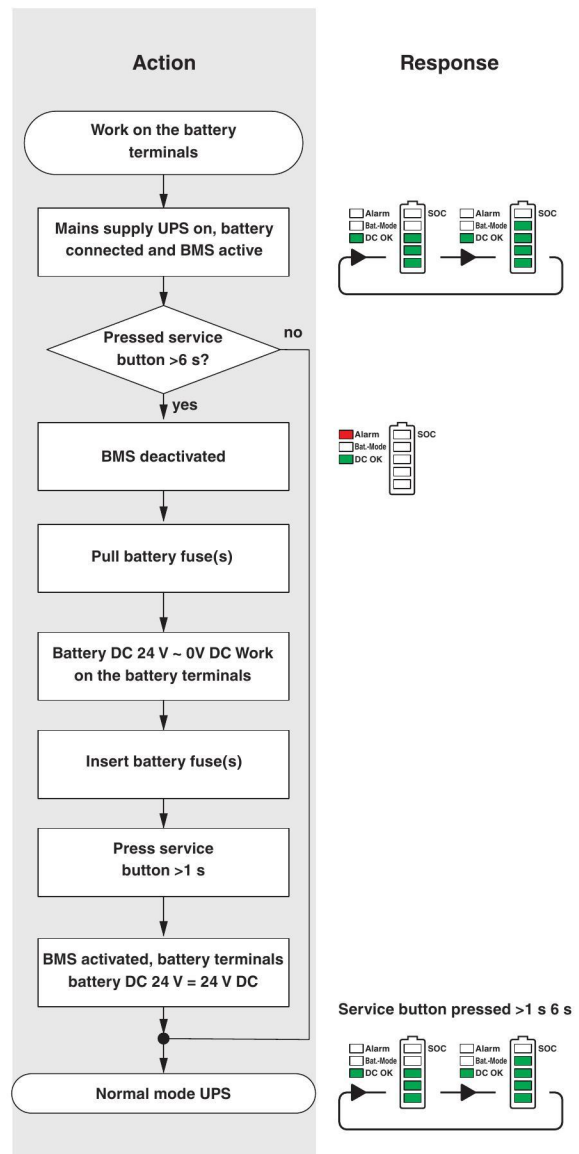

**i** Service mode must also be used when a battery needs to be replaced.

**Battery replacement**



**WARNING: Dangerous situations can arise in the event of incorrect installation or incorrect use.**

Observe the correct polarity during connection.

Do not short circuit the pole terminals.

The batteries are maintenance free. Opening them is not permitted.



To ensure the maximum available capacity and service life of the battery, always use new batteries from the same production batch when replacing batteries. When storing the batteries, always note the latest startup date. Depending on the storage time, recharging with a UPS may be necessary.

To replace a battery (battery blocks of battery module) proceed as follows:

1. Switch the UPS from mains operation to service mode (press and hold service button >6 seconds).
2. Check that the housing cover is secured with a cable tie to prevent it opening unintentionally. Remove any cable ties, if necessary.
3. Press the locking lugs on the housing top of the battery module. Then open the housing cover.
4. Remove all of the fuses from the battery module (see figure: Removing fuse).

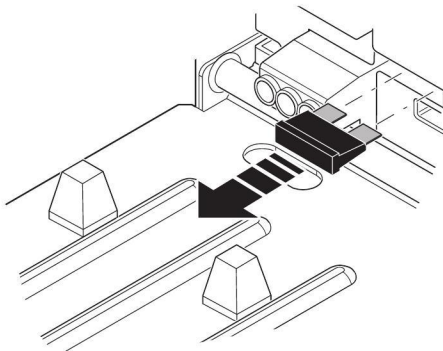

5. Check whether the connection terminal blocks on the UPS and battery DC 24 V (4.1, ..., 4.3) connection terminal blocks have been disconnected.
6. Disconnect the internal wiring from the battery blocks. Avoid short circuits.
7. Remove the installed battery blocks from the battery module and only replace them with identical ones.
8. Reconnect the internal wiring of the battery blocks. Ensure that the polarity is correct.

9. Insert all of the fuses into the battery module (see figure: Inserting fuse).

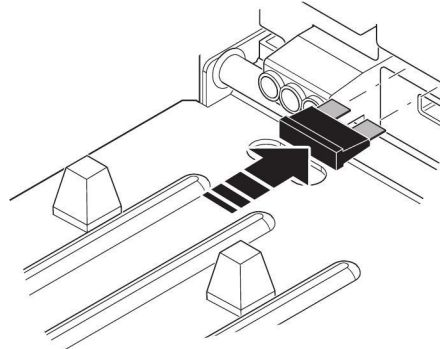

10. Close the housing cover so that none of the internal wiring is squashed and the locking lugs engage on the top of the housing.
11. Secure the housing cover of the battery module with a cable tie, for example, to prevent it opening unintentionally.
12. Switch the UPS from service mode back to mains operation (press and hold service button >1 seconds).



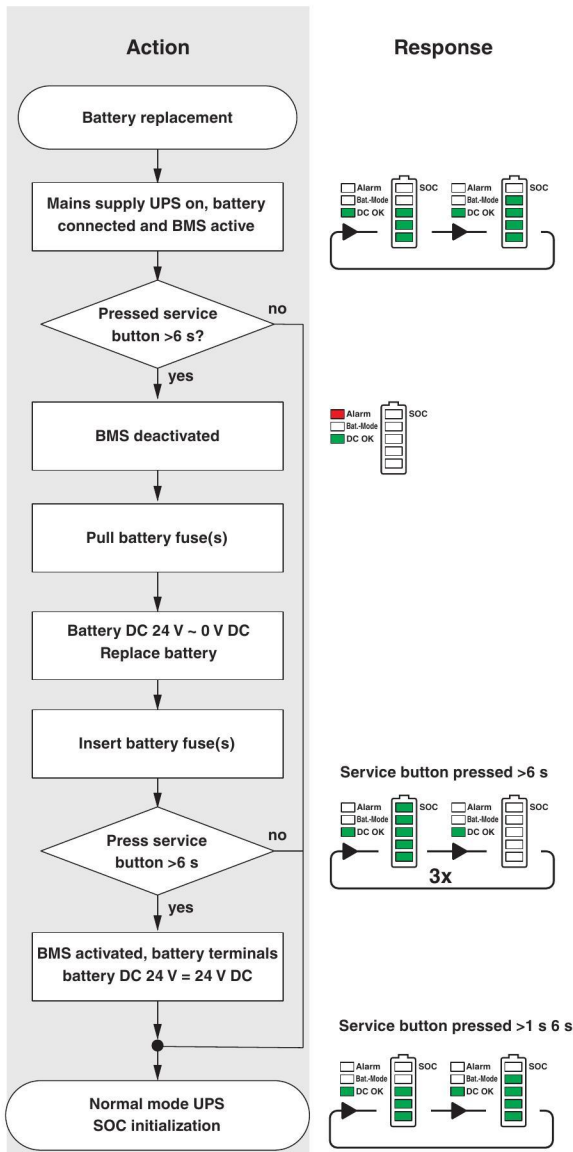

You can return used batteries and accumulators to Phoenix Contact or the manufacturer.

### 12.2.4 Signaling

Event	LED			Signal			LED bar graph
	Alarm red	Bat-Mode yellow	DC OK green	Alarm	Bat-Mode	Ready	
Input voltage is within the defined input voltage range No alarm state Phoenix Contact battery fully charged	0	0	1	H	L	H	1
Input voltage is within the defined input voltage range No alarm state Battery from other manufacturer fully charged	0	0	1	H	L	H	0
Remote state	0	0	B	H	L	H	1
Service mode	1	0	1	L	L	L	0
Exit battery replacement	1	0	1	L	L	L	B

0 = Off, 1 = On  
H = High, L = Low  
B = Flashing

### 12.3 Charging

The DC load connected to the DC output (2.1, 2.2) is continuously supplied with energy. The battery charger or BMS simultaneously manages the connected battery (battery DC 24 V 4.1, ..., 4.3). The state of charge of the battery is monitored continuously and the battery is recharged, if necessary.

The maximum charging current used to charge the battery is only limited by the performance levels of the device-internal battery charger of the UPS. The corresponding charging current adjusts itself depending on the current state of charge. The battery charging current reduces to zero when the battery is fully charged.

A fully discharged battery is initially charged with the maximum charging current. For this purpose, however, the PS Boost (3.7) signal input of the UPS must be connected to the DC-OK signal of the power supply. The PS Boost signal input is activated at a high level.

If you are using Phoenix Contact batteries, overcharging the batteries is not possible even if the maximum permissible charging current is exceeded. The battery management system (BMS) recognizes the battery type and the associated charging parameters and sets these independently.

UPS	Max. charging current
QUINT4-UPS/24DC/24DC/40/...	5 A



After replacing a battery, the UPS does not know the state of charge (SOC) of the Phoenix Contact battery. Once the battery has been fully charged, the SOC value and expected service life (state of health - SOH) are determined.



Ensure that the UPS and battery module (batteries) are not disposed of in the household waste. Only dispose of them in accordance with the applicable national regulations.



**12.3.1 Charge Phoenix Contact battery - SOC is determined**

When using a new Phoenix Contact battery, the UPS does not know the state of charge (SOC) of the battery. This means that the battery must be charged fully by the UPS during initial commissioning. The battery characteristics, such as the SOC value and expected service life (state of health - SOH) are determined during this process. The 5-line LED bar graph repeatedly lights up green from bottom to top until the battery has been fully charged.



Figure 32 Charging a new IQ energy storage device (unknown SOC)



The charging time of the battery depends on the capacity and power supplied by the UPS. The maximum charging time can last up to several hours.

**12.3.2 Charge Phoenix Contact battery - SOC is known**

The Phoenix Contact battery is fully charged by the UPS. The battery characteristics, such as the state of charge (SOC) or service life (state of health - SOH) are determined by the UPS. For this purpose, the Phoenix Contact battery must be fully charged at least once by the UPS. The 5-line LED bar graph lights up green one segment at a time depending on the current state of charge. The flashing segment indicates the active charging process.

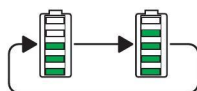

Figure 33 Battery charging (SOC is known)

**12.3.3 Batteries from other manufacturers – SOC is not displayed**

The extended battery characteristics cannot be determined if batteries from other manufacturers are used. The charging process is indicated by the lowest segment of the 5-line LED bar graph flashing green.



Figure 34 Charging batteries from other manufacturers

**12.3.4 PS Boost**

During mains operation, the upstream QUINT power supply supplies the DC load at the load output of the UPS (output 24 V DC 2.1, 2.2). The load on the power supply increases or decreases as the load changes. If the power supply is not operated via  $P_N$  (100%), the battery charger of the UPS provides the maximum charging current. For this purpose, connect the signal output of the power supply Out 2 ( $P_{OUT} < P_N$ ) with the signal input PS Boost (3.7) of the UPS. If the load requests an output power  $>P_N$  from the power supply, it switches to boost mode. The signal state of signal output OUT2 for the power supply simultaneously switches from active high to low. The low signal at signal input PS Boost (3.7) of the UPS ensures that the battery charger only supplies a reduced charging current.

As the output load is reduced to  $P_{OUT} < P_N$ , the signal output OUT2 of the power supply also switches back from the low signal to active high. The maximum charging current is then available to charge the battery again.

UPS	Red. charging current	Max. charging current
QUINT4-UPS/24DC/24DC/40/...	1.5 A	5 A



If you are using a standard UPS (without a communication interface), any signal changes are only displayed on the upstream QUINT power supply. If the UPS is also equipped with a communication interface, any signal changes are transferred to the UPS-CONF software via the communication protocol.



The reduced charging current is also supplied if the PS Boost (3.7) signal input is not connected.

**12.3.5 Function of the service button (service mode)**

Press and hold the service button for >6 seconds to terminate the battery charging process. The UPS switches to service mode. The corresponding alarm state is activated. A detailed description of using service mode is provided in the mains operation operating state.

**12.3.6 Signaling**

Event	LED			Signal			LED SOC bar graph
	Alarm	Bat.- Mode	DC OK	Alarm	Bat.- Mode	Ready	
	red	yellow	green				
Phoenix Contact battery charging SOC is determined	0	0	1	H	L	L	Upward running light
Battery from other manufacturer is charging No SOC display	0	0	1	H	L	L	Lower LED is flashing
Phoenix Contact battery charging SOC is known	0	0	1	H	L	L	Current SOC LED flashing, charging on, not yet reached off: fully charged status LEDs on, discharge status LEDs off, current level LED flashing

0 = Off, 1 = On  
H = High, L = Low

**12.4 Battery operation**

**12.4.1 Functions of the rotary selector switch**

In the event of an incident, the behavior of the UPS can be set via the 10-stage rotary selector switch  $t_{max}$  [min] on the front of the device. Depending on the application in your system, select between time-limited operation (1, ..., ∞) or another function (PC mode). PC mode can only be selected for UPS versions with a communication interface.

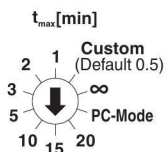

Figure 35 Rotary selector switch (UPS with communication interface)

**12.4.2 Actuation thresholds**

The actuation thresholds are factory defaults that define battery operation or mains operation when mains power is restored. The UPS switches to battery operation when the threshold falls below the permissible minimum input voltage. Battery operation is started without a delay when an input voltage of <22.5 V DC is detected at the input terminals DC 24 V (1.1, 1.2).

The DC load connected to the output DC 24 V (2.1, 2.2) connection terminal blocks will continue to be supplied without any interruption.

Factory-set actuation thresholds at the input DC 24 V (1.1, 1.2) connection terminal blocks:

Threshold	Switch-over function
$U_{IN} < 22.5$ V DC	Mains operation during battery operation
$U_{IN} > 23.5$ V DC (min. 3 s)	Battery operation during mains operation



The actuation thresholds can be adjusted individually using the UPS-CONF configuration software. For additional information, refer to the relevant user manual.

**12.4.3 Output/supply of the load**

During battery operation, the output voltage is directly dependent on the battery voltage. When mains power is restored, the UPS automatically returns to mains operation. The connected loads are again supplied via the power supply network and the battery is charged at the same time.

### 12.4.4 Remote

The remote function deactivates battery operation of the UPS. If you would like to use the remote state, the digital remote input (3.6) must be connected to the SGnd (3.9) signal terminal.

This state is terminated immediately if the UPS is operated in battery mode. The output terminals DC 24 V (2.1, 2.2) are disconnected and the UPS is also switched to standby mode. This procedure cannot be reversed.

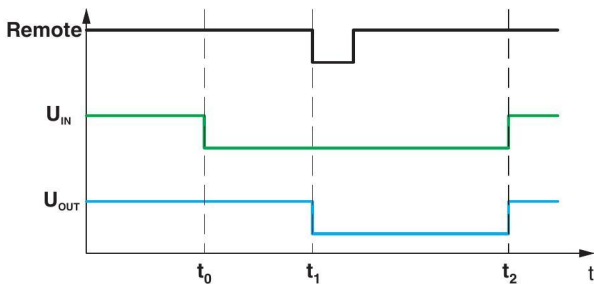

Time	Event
t <sub>0</sub>	Mains power failure
t <sub>1</sub>	The remote signal is set in buffer mode, the output is switched off.
t <sub>2</sub>	The input voltage is restored and the output is switched on.



Application example: main switch for shutdown (default)

By default, battery operation is permanently enabled for universal UPS applications. Connect the remote input (3.6) to the SGnd potential (3.9) via an auxiliary contact on the main switch (N/C contact).

If the system is now switched off via the main switch, the UPS is also fully deactivated.

### 12.4.5 Function of the service button



The service button is deactivated during battery operation. Service mode can therefore not be selected.

### 12.4.6 Signaling

Event	LED			Signal			LED SOC bar graph
	Alarm red	Bat.- Mode yellow	DC OK green	Alarm	Bat.- Mode	Ready	
Phoenix Contact battery is discharged No alarm state SOC known	0	1	0	H	H	H	in accordance with general SOC state
Phoenix Contact battery is discharged No alarm state SOC unknown	0	1	0	H	H	H	Downward running light
Battery from other manufacturer is discharged No alarm state No SOC display	0	1	0	H	H	H	0

0 = Off, 1 = On  
H = High, L = Low

### 12.5 Standby

Battery operation is terminated, if shutdown conditions, such as deep discharge protection, timer elapses, etc. occur during battery operation. In this case, terminated means that the DC output (2.1, 2.2) is switched off and the load is no longer supplied. The UPS then switches to standby mode. In standby mode, any alarms that arise are indicated by the LED status indicator or the signal contact.

Data continues to be exchanged if the UPS is equipped with a communication interface.

### 12.5.1 Signaling

Event	LED			Signal			LED
	Alarm	Bat.- Mode	DC OK	Alarm	Bat.- Mode	Ready	SOC bar graph
	red	yellow	green				
Phoenix Contact battery is discharged No alarm state SOC known	0	1	0	H	H	H	in accordance with general SOC state
Phoenix Contact battery is discharged No alarm state SOC unknown	0	1	0	H	H	H	Downward running light
Battery from other manufacturer is discharged No alarm state No SOC display	0	1	0	H	H	H	0

0 = Off, 1 = On  
H = High, L = Low

### 12.6 UPS off

The UPS switches off completely when the standby time expires.



### 13 Battery management system (BMS)

The battery management system (BMS) automatically recognizes and adapts when Phoenix Contact batteries with IQ Technology are used.

The following battery storage technologies are available for this purpose:

- Lead-acid batteries (VRLA)
- Lithium batteries

The BMS automatically recognizes the battery type and battery storage technology being used so that no additional settings are required, making it particularly user-friendly. The BMS continuously monitors the battery status and provides information about the current state of charge (SOC) and state of health (SOH). The battery temperature is monitored, the block and cell voltage is checked for under- or overvoltages, and the complete battery charging process is controlled.



The BMS automatically recognizes the optimum charging characteristics when Phoenix Contact batteries with IQ Technology are used.

#### 13.1 Battery charger

Depending on the performance class of the UPS, the integrated battery charging unit can have the following maximum charging current that can be used to charge the battery.

Product designation	Order No.	Max. charging current
QUINT4-UPS/24DC/24DC/40	2907077	5 A
QUINT4-UPS/24DC/24DC/40/USB	2907078	
QUINT4-UPS/24DC/24DC/40/PN	2907079	
QUINT4-UPS/24DC/24DC/40/EIP	2907080	
QUINT4-UPS/24DC/24DC/40/EC	2907081	



To dimension the power supply correctly, you must determine the total current consumption of the system being supplied. The total current consumption is made up of the maximum battery charging current and the maximum load current.

#### 13.1.1 Charging characteristic

The IUoU charging characteristics used to charge the battery is supported by the three-stage battery charger or its charge controller. The individual charging phases of the battery's three-stage charge controller are shown in the following diagram.

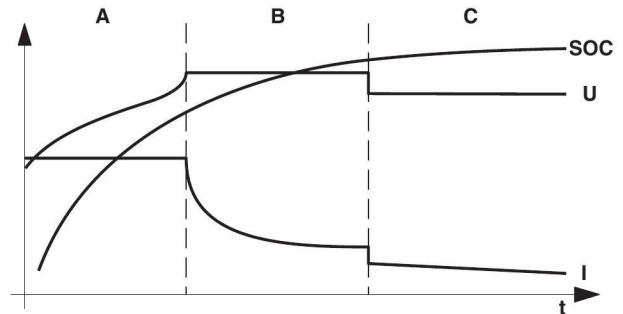

Figure 36 3-stage charging procedure based on IUoU charging characteristic

#### Key

Stage	Charging designation	Short description
A	Main charge	Constant current charging phase (CC), initial charging current
B	Compensation charging	Constant voltage charging phase (CV), compensation trickle charge voltage
C	Trickle charging	Constant voltage charging phase (CV), trickle charging final voltage

#### 13.1.2 Battery charging time

The battery recharging time is dependent on the maximum battery charging current and the total capacity of the battery. If, for example, n batteries are connected in parallel to increase the capacity, the recharging time is n times as long.



A maximum of five batteries of the same type may be connected in parallel to increase the total capacity.



### 13.1.3 Battery technologies

In the event of a fault, Phoenix Contact will use lead-acid batteries (VRLA) and lithium batteries to supply the load to your system. Additional information on the battery technologies that are used, is provided in the following sections.

#### 13.1.4 Lead-acid battery

The valve regulated lead acid (VRLA) battery is a lead-acid battery in an enclosed plastic housing. The battery housing is fitted with a pressure relief valve for safety in the event of a technical fault during charging, for example, caused by an excessive build-up of gas.

If excess pressure builds up in the battery housing when charging the battery, it is released in a controlled manner via the pressure relief valve. This ensures that the battery housing will not break and the battery will not be destroyed.

Lead-acid batteries are always charged with a continuous compensation charge regardless of which technology is used, e. g. absorbent glass mat (AGM) or classic (refillable).



In contrast to the classic version, AGM batteries are maintenance free.

#### 13.1.5 Lithium battery

The lithium batteries stand out for their main characteristics. In comparison to lead-acid batteries, they are considerably lighter and are suitable for use at low temperatures (-40°C to +50°C). The high performance levels of lithium batteries is even retained during long storage periods of up to ten years.

### 13.2 Batteries from other manufacturers

The use of batteries from other manufacturers is generally possible. However, please note that the full scope of performance of the BMS with IQ Technology is not supported.

Phoenix Contact batteries from the UPS-BAT series also have a separate signal terminal to communicate with the UPS. If this signal terminal is not connected, the temperature cannot be compensated independently by the battery. In this case, the temperature is measured by the UPS instead.



If batteries from other manufacturers are used, the battery charging parameters must be adjusted manually.

The charge parameters must be monitored on a continuous basis to ensure the battery is not damaged during the charging process.

The manufacturer-specific charging parameters of the batteries being used must be parameterized in the UPS-CONF configuration software (Order No. 2320403) in the UPS.

### 13.3 Battery storage

Until ready for use, store the batteries in a cool, dry place wherever possible to ensure that the battery capacity is not reduced. Store the batteries in the original packaging and avoid additional extreme temperatures or temperature fluctuations within the storage facility.



#### NOTE: Requirements for the storage facility

Certain rules must be observed when storing Cat. 2 batteries (medium capacity batteries >1 kg, <60 V). Lithium batteries must be stored separately from the hazardous material store or clearance areas wherever possible. Category D fire extinguishers must be provided.



#### NOTE: Battery capacity

The batteries must be fully charged to ensure you can insert a fully functioning UPS system in your application from the outset.

Please note that the batteries are fully charged again every time they are used during the planning, production, or acceptance phase.

When dispatching the UPS system, also remove the relevant ATO fuses to protect the batteries from discharging. More detailed information is provided in the relevant product documentation for the battery.

## 14 Interfaces

Depending on the UPS version that is used, data can be exchanged via an electrically isolated communication interface. The communication interface is located on the underside of the UPS.

Upon delivery of the UPS, all configurable versions are supplied with the corresponding default settings.

Data is exchanged between the UPS and higher level PC or controller.

The following options are available for the determined and collected data:

- Status monitoring
- Energy monitoring
- Diagnostics
- Configuration
- PC shutdown



Data is either accessed cyclically (implicit) or on a continuous basis/acyclically (explicit) or when a function is executed.

### 14.1 USB

The USB communication relies on a point-to-point coupling. For communication purposes, USB data cables with a maximum connection length of 5 meters are generally permitted. A prerequisite is that the USB data cable meets the USB 2.0 standard. The connector must be a mini USB type B version.

The Phoenix Contact connection cable (2908217) with a connection length of 3 m is a mini USB type B version. Two mounting screws on the connector ensure it can also be used for industrial applications.

The use of active USB cables or USB extenders to increase the communication line is not permitted. These can cause faulty data connections and disrupt the communication.

A supply voltage must be connected to be able to configure the UPS and communicate with it. The source of the supply to the UPS is irrelevant. The supply voltage can either be supplied by the upstream power supply (mains operation) or by the connected battery (bat. mode).

### 14.2 PROFINET

The use of RJ45 extension cables for increasing the communication path can lead to faulty data connections. The use of RJ45 extension cables is therefore not permitted.

#### 14.2.1 Signaling

QUINT4-UPS/24DC/24DC/.../PN	LED			
	BF	SF	LNK1	LNK2
	red	red	green	green
UPS off	0	0	0	0
UPS started Default settings loaded No RJ45 cable connected No IP address assigned No master connected	1	1/0	0	0
UPS started Default settings loaded RJ45 cable is connected IP address is being assigned No master connected	B	1/0	0	1/0
UPS started Default settings loaded RJ45 cable is connected IP address is assigned Master is connected	0	1/0	1	1/0

0 = Off, 1 = On  
 1/0 = On/Off (both versions possible, not relevant)  
 B = Flashing

14.2.2 Phoenix Contact PC WORX 6

1. Load the device description catalog FDCML\_Catalog\_POWER\_xx.zbcc (International) from the download area of the UPS.
2. Then import the device description catalog into the engineering tool. To do so, switch to the Bus Configuration Workspace view. Select any entry in the tree structure of the device catalog. Execute the *Import Catalog...* command via the sidekick menu.

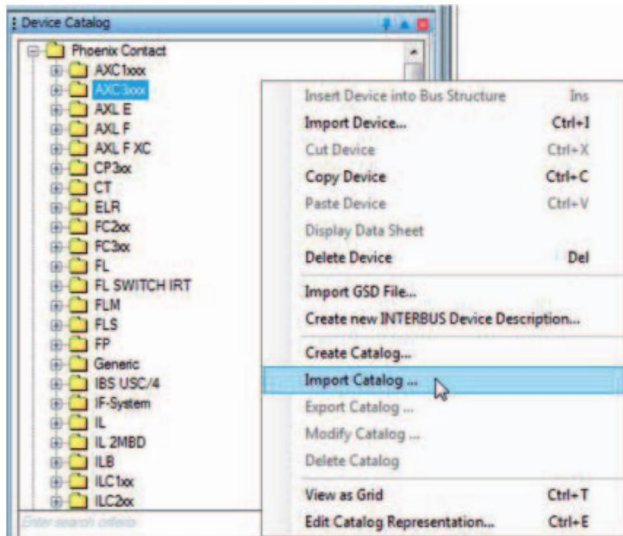

3. Create the new hardware configuration by double clicking on the required UPS in the device catalog.

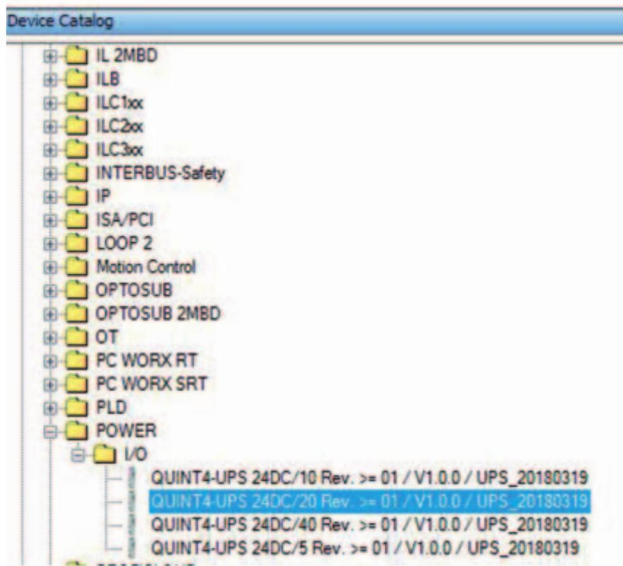

4. The new UPS hardware configuration is automatically added to the bus structure during this process.

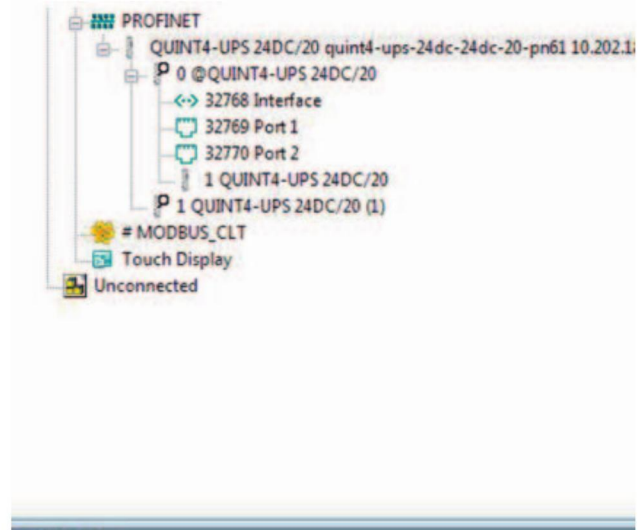

5. Do the same in the module catalog for the required battery module.
6. Download the PCW\_6\_PowerSupplies\_xx library and open it by double clicking.
7. Follow the instructions in the installation menu.

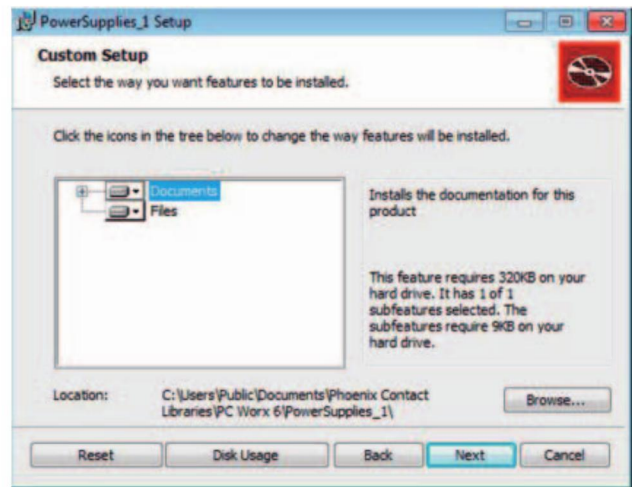



8. Select the libraries entry in the project tree. Add the new library via the *Insert>User Library* sidekick menu.

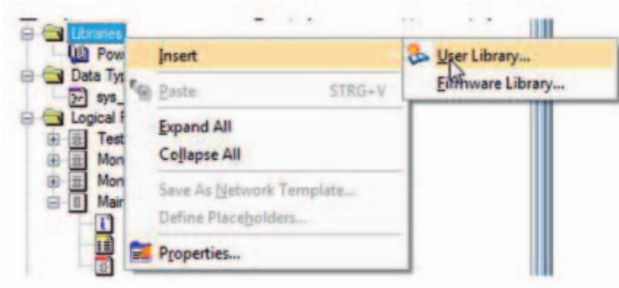

### 14.2.3 Siemens TIA portal

1. Download the device description file: *GSDML-V2.34-Phoenix\_Contact-UPS-YYYYMMDD.xml* (English).
2. Add the device description file via the *Manage device description files* item in the Extras menu.

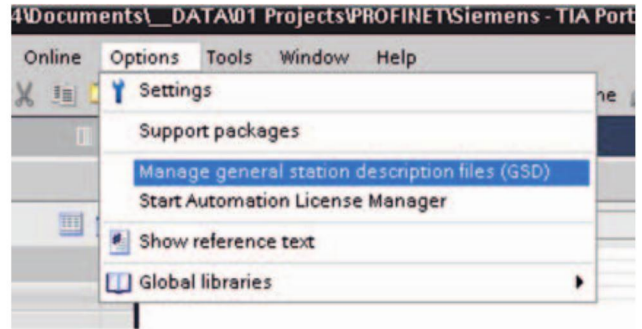

3. Select the device description file in the download folder. Confirm with the [Install] button.

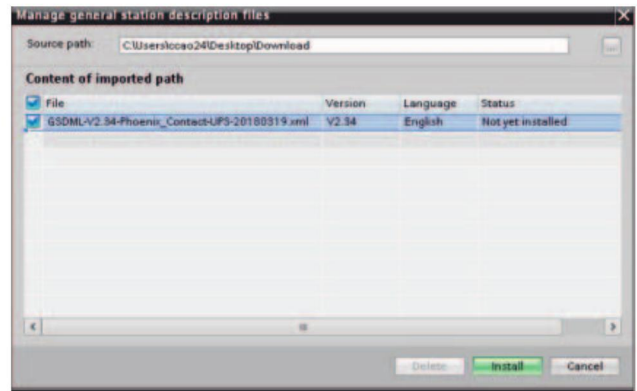

4. Add the device to the network configuration via the tree structure of the device catalog.

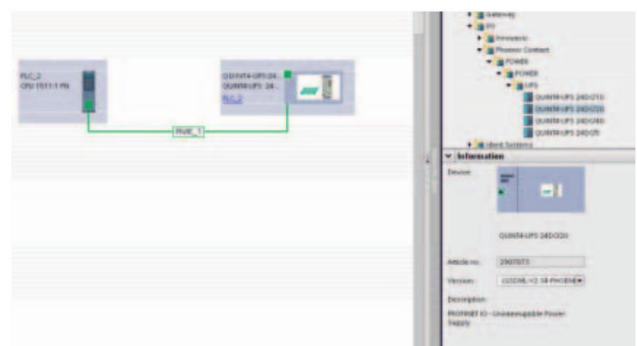

- Download *library S7\_PowerSupplies\_xx*.
- Select the libraries tab on the right-hand side.
- Add the library via the [Open global library] button in the library tab.

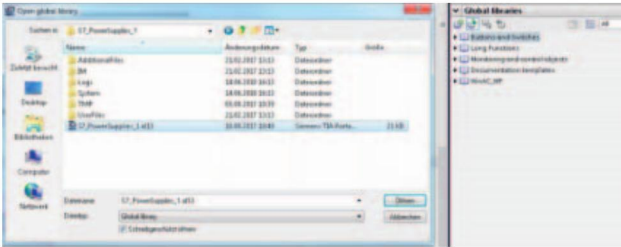

### 14.3 EtherNet/IP™

The use of RJ45 extension cables for increasing the communication path can lead to faulty data connections. The use of RJ45 extension cables is therefore not permitted.

#### 14.3.1 Signaling

QUINT4-UPS/24DC/24DC/.../EIP	LED			
	NET	MOD	LNK1	LNK2
	green/red	green/red	green	green
UPS off	0	0	0	0
UPS started Default settings loaded No RJ45 cable connected No IP address assigned No master connected	0	1	0	0
UPS started Default settings loaded RJ45 cable is connected No IP address assigned No master connected	0	1	1	1/0
UPS started Default settings loaded RJ45 cable is connected IP address is assigned No master connected	B	1	1	1/0
UPS started Default settings loaded RJ45 cable is connected IP address is assigned Master is connected	1	1	1	1/0

0 = Off, 1 = On  
 1/0 = On/Off (both versions possible, not relevant)  
 B = Flashing

#### 14.3.2 Rockwell LogixDesigner

- Download the relevant device description file  
*PHOENIXCONTACT\_QUINT4\_DC-UPS\_5A\_EIP.xml*  
*PHOENIXCONTACT\_QUINT4\_DC-UPS\_10A\_EIP.xml*  
*PHOENIXCONTACT\_QUINT4\_DC-UPS\_20A\_EIP.xml*  
*PHOENIXCONTACT\_QUINT4\_DC-UPS\_40A\_EIP.xml*
- Open the EDS Hardware Installation Tool

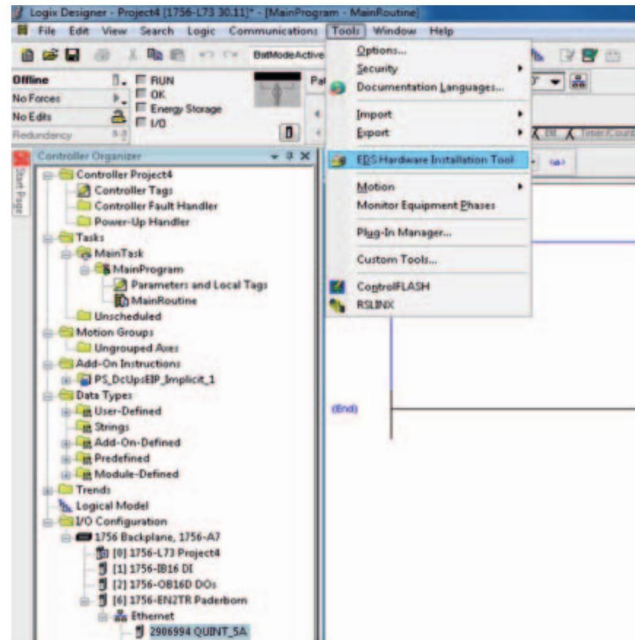

#### 3. Registration of EDS files

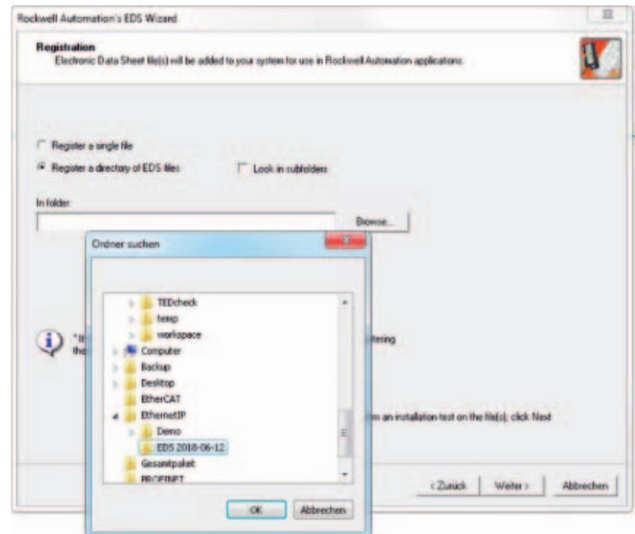



4. Create a new module in the Controller Organizer by right clicking on *Ethernet* and selecting *New Module*

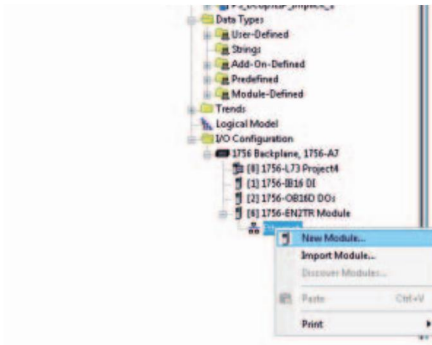

5. Search for the device using the search term *QUINT*. Select suitable UPS.

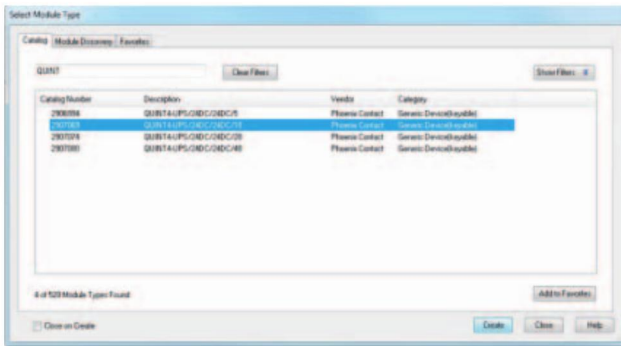

6. Download the import file *PowerSupplies\_xx.L5K*.
7. Import the *Add On Instruction* by right clicking on *Add On Instruction* in the Controller Organizer.

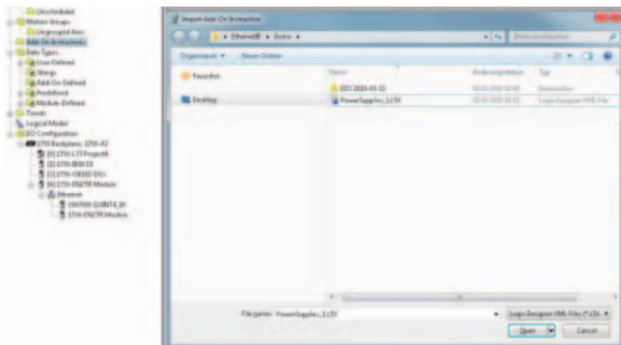

## 14.4 EtherCAT®

The use of RJ45 extension cables for increasing the communication path can lead to faulty data connections. The use of RJ45 extension cables is therefore not permitted.

### 14.4.1 Signaling

QUINT4-UPS/24DC/24DC/.../EC	LED			
	RUN	ERR	L/A1	L/A2
	green	red	green	green
UPS off	0	0	0	0
UPS started Default settings loaded No RJ45 cable connected No master connected No master data traffic	0	0	0	0
UPS started Default settings loaded RJ45 cable is connected (initialization) No master connected No master data traffic	0	0	0	(B)
UPS started Default settings loaded RJ45 cable is connected Master connected (pre-operational) No master data traffic	B	(0)	B	(B)
UPS started Default settings loaded RJ45 cable is connected Master connected Master data traffic (operational)	1	(0)	B	(B)

0 = Off, 1 = On  
1/0 = On/Off (both versions possible, not relevant)  
B = flashing, (B) = (flashing, not relevant)

### 14.4.2 Beckhoff TwinCAT 3

Proceed as follows to add the xml-based device description file to your TwinCAT control software:

1. Open the Phoenix Contact website and browse to the required UPS version or its download area.
2. Depending on the performance class, the following device description files are available for the UPS versions in the download area.
  - PHOENIXCONTACT\_QUINT4\_DC-UPS\_5A\_EC\_YYYYMMDD.xml
  - PHOENIXCONTACT\_QUINT4\_DC-UPS\_10A\_EC\_YYYYMMDD.xml
  - PHOENIXCONTACT\_QUINT4\_DC-UPS\_10A\_EC\_YYYYMMDD.xml
  - PHOENIXCONTACT\_QUINT4\_DC-UPS\_40A\_EC\_YYYYMMDD.xml

- Select a suitable device description file and copy it into the TwinCAT controller folder. If you have not changed the default settings of the TwinCAT control software, the directory will still be `C:\TwinCAT\X.X\Config\Io\EtherCAT`.

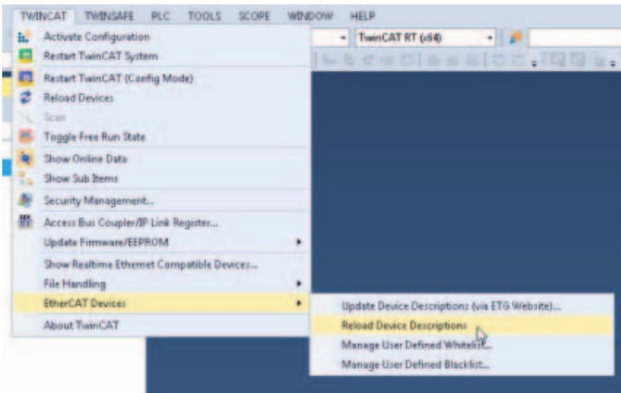

- Execute the *Reload Device Descriptions* command.

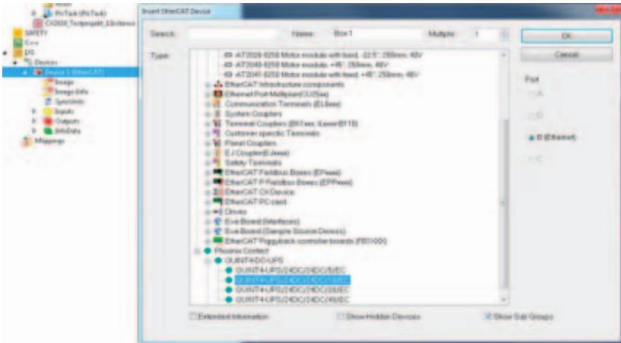

- Use the *Add New Item* command to add the new device to the UPS version.
- Then load the *PowerSupplies\_xx.compiled-library* library.

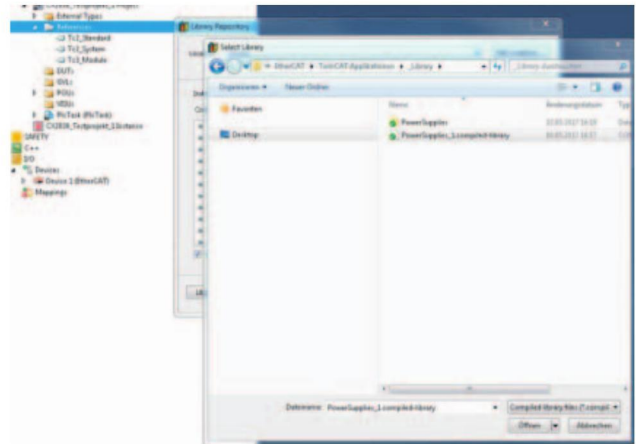
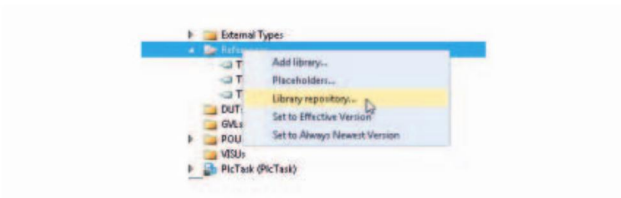

- Following the download, install the function blocks from the library *PowerSupplies\_xx.compiled-library*.
- Then add the new function blocks to the TwinCAT control software.

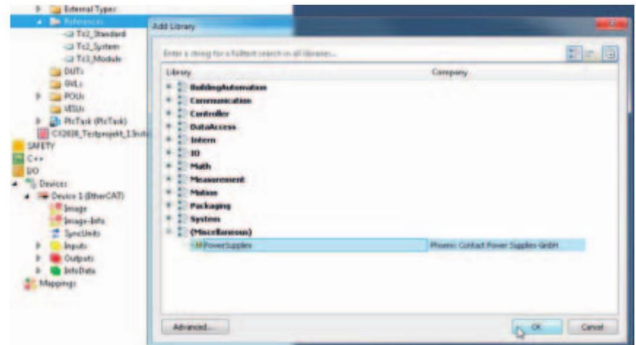

## 15 Application example

### 15.1 Wiring the signal level

#### 15.1.1 Alarm, PS Boost

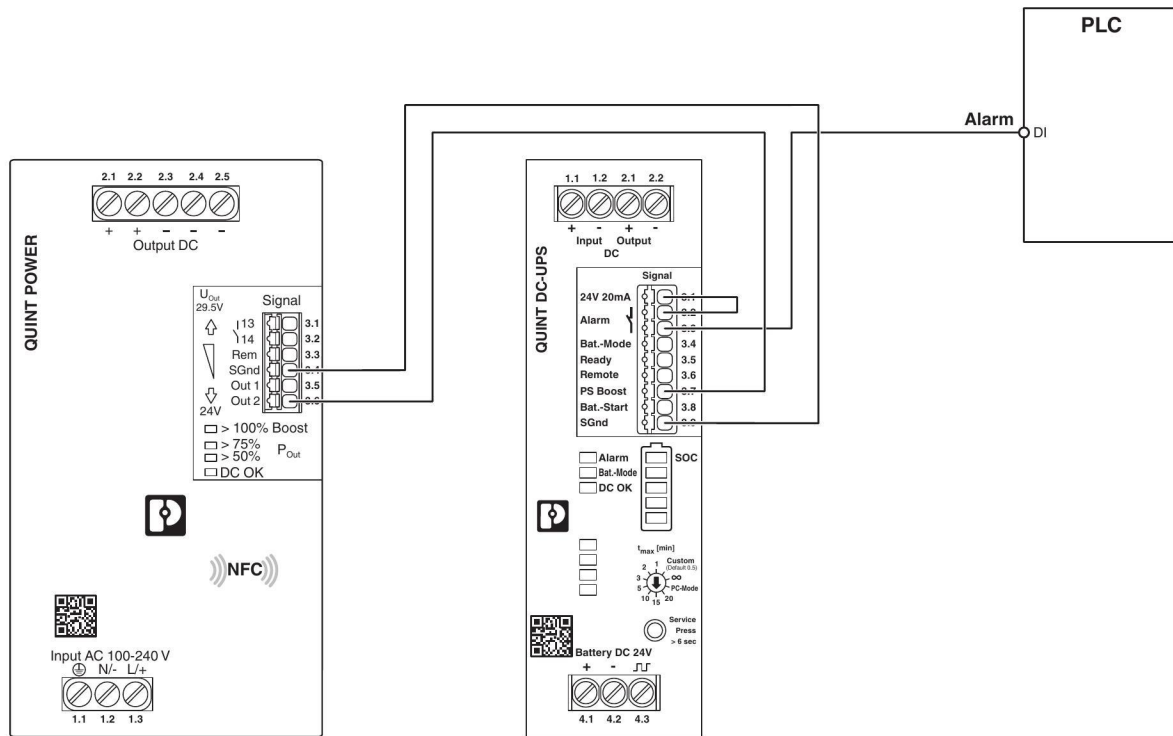

15.1.2 Alarm, PS Boost, Bat.-Mode, Ready

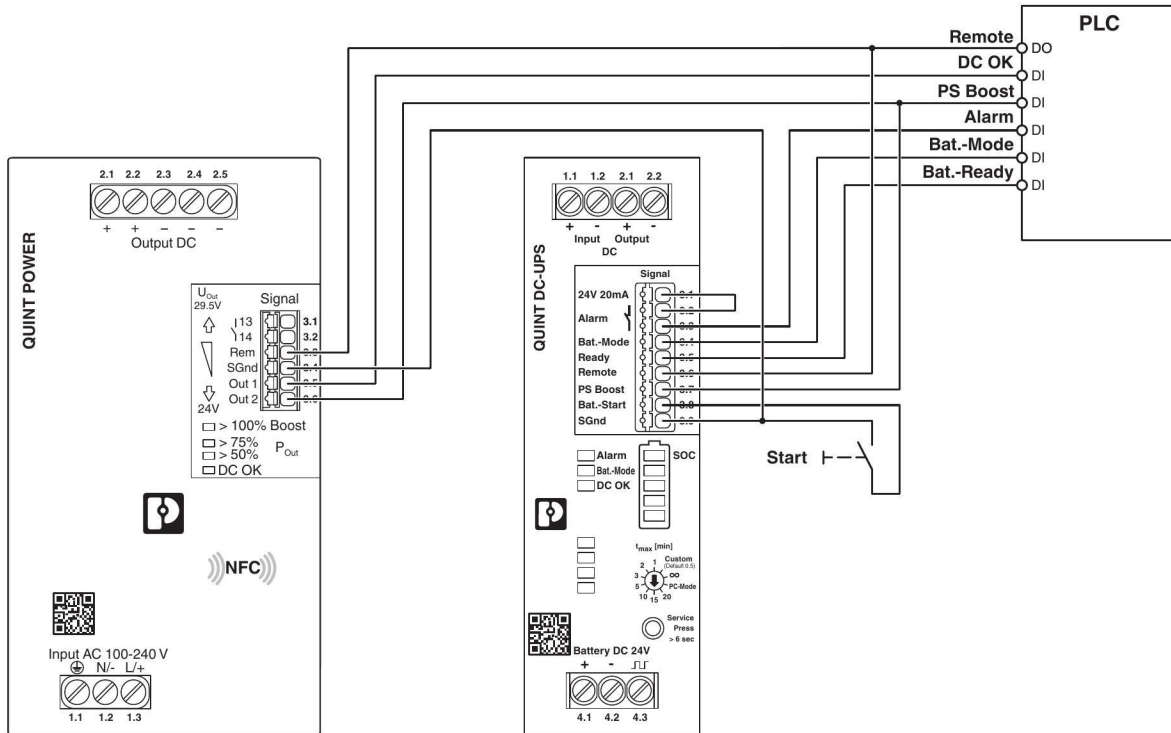

15.2 Parallel connection of batteries

Please note the following points for the set-up and wiring:

1. Install the batteries in the control cabinet in as cool a location as possible.
2. Position the potential-based support terminals as close to the batteries as possible.
3. Install a separate fuse in close proximity to the 24 V support terminals to protect the 24 V live wiring. The selected fuse rating must be able to sustain the sum of the partial currents of the individual batteries.
4. Always use the same wire lengths with identical wire cross sections when connecting the support terminals and batteries. Observe the required current carrying capacity when dimensioning the wiring.
5. Always use the same wire lengths with identical wire cross sections when connecting the UPS and support terminals. Observe the required current carrying capacity when dimensioning the wiring.
6. The wire cross section used to connect the signal terminal between the UPS, support terminals, and batteries should be at least 0.75 mm<sup>2</sup>.

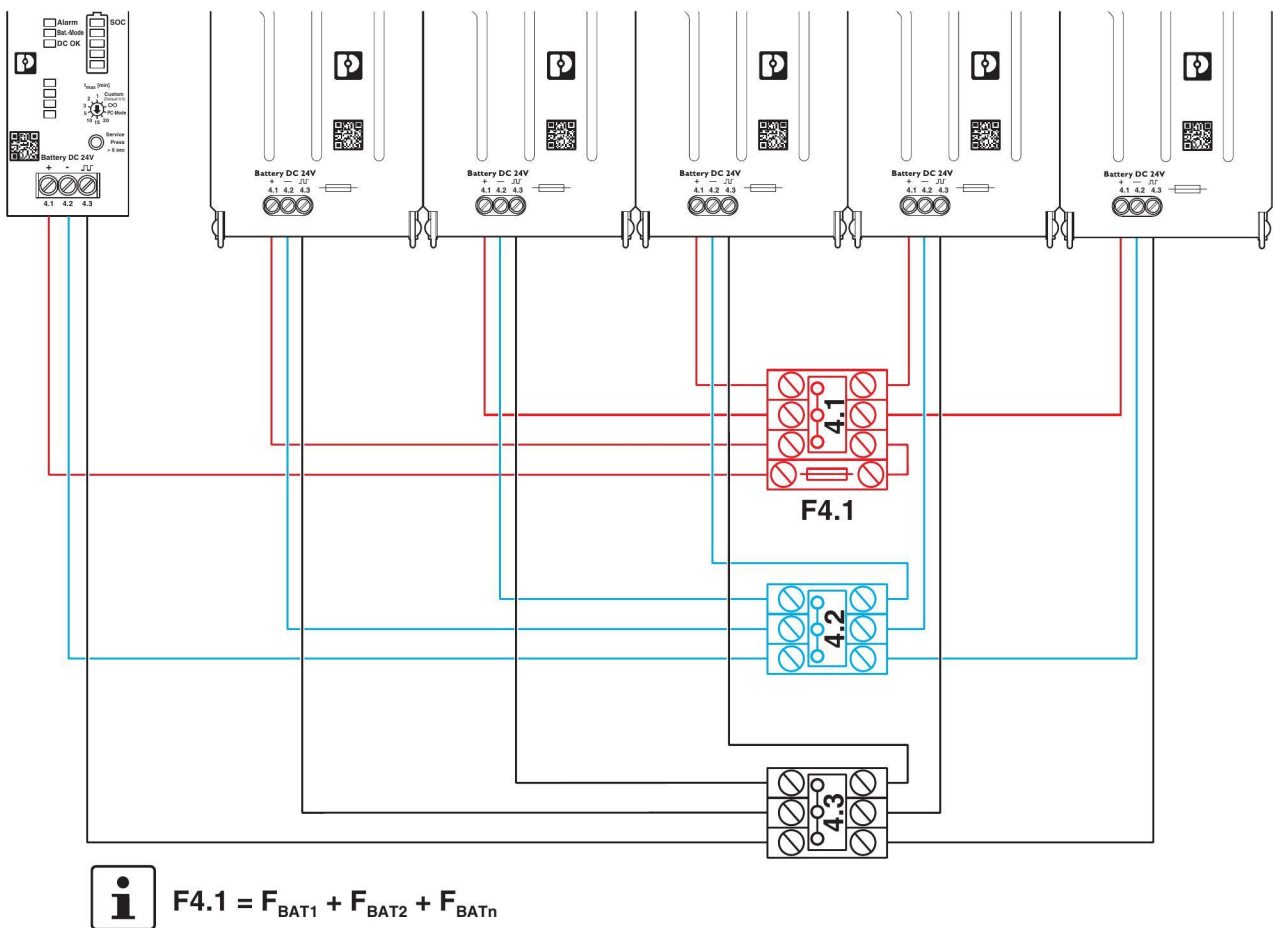

Figure 37 Schematic wiring structure during parallel operation of batteries



## 16 Attachment – Register tables



This documentation applies to all Ethernet-based QUINT-UPS versions with a communication interface (2x RJ45 interface). The parameters listed here describe the addressing for the Profinet, Ethernet/IP and EtherCAT® protocol.

### 16.1 Information

Address [hex]			Name	Unit	Min.	Max.	Default Byte	Size	Access
PN	EIP	EC							
0x0004	0x0001	0x2004	FW Version	--	0x0000	0xFFFF	0x0000	2	RO
0x0005	0x0002	0x2005	Serial number	--	0x0000000000000000	0xFFFFFFFFFFFFFFFF	0x0000000000000000	8	RO

### 16.2 Configuration

Address [hex]			Name	Unit	Min.	Max.	Default Byte	Size	Access
PN	EIP	EC							
0x1000	0x0003	0x3000	User device name	--				32	RW
0x1020	0x0004	0x3020	User system name	--				32	RW
0x1040	0x0005	0x3040	Set parameters	Code	0x00000000	0xFFFFFFFF	0x01901020	4	RW
0x1042	0x0006	0x3042	Set signaling code DO 1	Code	0x00000000	0xFFFFFFFF	0x00001002	4	RW
0x1044	0x0007	0x3044	Set signaling code DO 2	Code	0x00000000	0xFFFFFFFF	0x00800000	4	RW
0x1046	0x0008	0x3046	Set signaling code DO 3	Code	0x00000000	0xFFFFFFFF	0x20000000	4	RW
0x104A	0x0009	0x304A	Set function code DI 1	Code	0x0000	0xFFFF	0x0002	2	RW
0x104B	0x000A	0x304B	Set function code DI 2	Code	0x0000	0xFFFF	0x0008	2	RW
0x104D	0x000B	0x304D	Set charge current UPS 5A	mA	200	1500	1500	2	RW
			Set charge current UPS 10A	mA	200	3000	3000	2	RW
			Set charge current UPS 20A	mA	200	5000	5000	2	RW
			Set charge current UPS 40A	mA	200	5000	5000	2	RW
0x000B	0x000C	0x304E	Set charge absorption voltage	mV	2500	32000	28000	2	RW
0x104F	0x000D	0x304F	Set charge end voltage	mV	2500	32000	27600	2	RW
0x1050	0x000E	0x3050	Set battery temp coefficient	mV	0	200	42	2	RW
0x1051	0x000F	0x3051	Set discharge battery endvoltage	mV	1800	24000	19200	2	RW
0x1056	0x0011	0x3056	Set switching threshold input voltage min	mV	1800	30000	22000	2	RW
0x1057	0x0012	0x3057	Set switching threshold input voltage max	mV	2000	32000	30000	2	RW
0x1058	0x0013	0x3058	Set batmode return to mains time	s	0	60	0	2	RW
0x1059	0x0014	0x3059	Set custom buffertime	s	3	65535	30	2	RW
0x105A	0x0015	0x305A	Set batmode delaytime 1 pc-shutdown	s	5	65535	60	2	RW
0x105B	0x0016	0x305B	Set batmode delay time 2	s	5	65535	10	2	RW
0x105C	0x0017	0x305C	Set batmode delay time 3	s	5	65535	10	2	RW
0x105D	0x0018	0x305D	Set pc mode shutdown time	s	1	3600	120	2	RW
0x105E	0x0019	0x305E	Set pc mode reset time	s	0	60	10	2	RW
0x105F	0x001A	0x305F	Set signaling time after switch off	s	0	36000	600	2	RW
0x1061	0x001B	0x3061	Set threshold buffer ready	%	0	100	100	2	RW
0x1062	0x001C	0x3062	Set batmode usable capacity	%	20	50	disabled	2	RW
0x1063	0x001D	0x3063	Set user installed peripherie	Code	1	65535	65535	2	RW
0x1064	0x001E	0x3064	Set bat user installed capacity nominal UPS 5A	100 mAh	8	65535	65535	2	RW
			Set bat user installed capacity nominal UPS 10A	100 mAh	13	65535	65535	2	RW
			Set bat user installed capacity nominal UPS 20A	100 mAh	30	65535	65535	2	RW

Address [hex]			Name	Unit	Min.	Max.	Default	Size	Access
PN	EIP	EC					Byte		
			Set bat user installed capacity nominal UPS 40A	100 mAh	70	65535	65535	2	RW
0x1067	0x001F	0x3067	Set test interval bat conductance	h	1	336	4	2	RW
0x1068	0x0020	0x3068	Set bat alarm user replace time	24 h	90	9125	disabled	2	RW
0x1069	0x0021	0x3069	Set bat alarm SOC voltage	mV	18000	30000	20400	2	RW
0x106A	0x0022	0x306A	Set bat alarm SOC percent	%	1	100	10	2	RW
0x106B	0x0023	0x306B	Set bat alarm SOC time	min	1	60	disabled	2	RW
0x106C	0x0024	0x306C	Set bat alarm SOH percent	%	1	100	disabled	2	RW
0x106D	0x0025	0x306D	Set bat alarm SOH time	24 h	30	365	182	2	RW
0x106E	0x0026	0x306E	Set bat warning SOC voltage	mV	18000	30000	disabled	2	RW
0x106F	0x0027	0x306F	Set bat warning SOC percent	%	1	100	disabled	2	RW
0x1070	0x0028	0x3070	Set bat warning SOC time	min	1	60	disabled	2	RW
0x1071	0x0029	0x3071	Set bat warning SOH percent	%	1	100	disabled	2	RW
0x1072	0x002A	0x3072	Set bat warning SOH time	24 h	30	365	disabled	2	RW
0x1073	0x002B	0x3073	Set battery warning delta temperature	K	5	40	disabled	2	RW
0x1074	0x002C	0x3074	Set mode selector switch	Code	0	9	disabled	2	RW
0x1076	0x002D	0x3076	Set enable disable function	Code	0x00000000	0x000004C1	0xFFFFFFFF	4	RW
0x1078	0x002E	0x3078	Set battery internal resistor max	mΩ	0x0000	0xFFFF	0xFFFF	2	RW
0x1079	0x002F	0x3079	Set resistor between ups and battery	mΩ	0x0000	0xFFFF	0xFFFF	2	RW

### 16.3 Status

Address [hex]			Name	Unit	Min.	Max.	Default	Size	Access
PN	EIP	EC					Byte		
0x2000	0x0030	0x4000	Battery 1 FW version	Code	--	--	--	4	RO
0x2002	0x0031	0x4002	Status interface	Code	--	--	--	4	RO
0x2004	0x0032	0x4004	Status actual input voltage	mV	--	--	--	2	RO
0x2005	0x0033	0x4005	Status actual input current	mA	--	--	--	2	RO
0x2006	0x0034	0x4006	Status actual output voltage 1	mV	--	--	--	2	RO
0x2007	0x0035	0x4007	Status actual output current 1	mA	--	--	--	2	RO
0x200A	0x0036	0x400A	Status battery actual voltage	mV	--	--	--	2	RO
0x200B	0x0037	0x400B	Status battery charge current	mA	--	--	--	2	RO
0x200D	0x0038	0x400D	Status battery temperature	K	--	--	--	2	RO
0x200E	0x0039	0x400E	Status device temperature	K	--	--	--	2	RO
0x200F	0x003A	0x400F	Status SOC	%	--	--	--	2	RO
0x2010	0x003B	0x4010	Status SOC remaining time	s	--	--	--	4	RO
0x2012	0x003C	0x4012	Status SOC remaining time pc-shutdown	s	--	--	--	2	RO
0x2013	0x003D	0x4013	Status SOH	%	--	--	--	2	RO
0x2014	0x003E	0x4014	Status SOH remaining lifetime	24h	--	--	--	2	RO
0x2015	0x003F	0x4015	Status installed peripherie	Code	--	--	--	2	RO
0x2018	0x0040	0x4018	Count operation time	s	--	--	--	2	RO
0x201A	0x0041	0x401A	Count user operation time	s	--	--	--	4	RW
0x201C	0x0042	0x401C	Count system start	--	--	--	--	4	RO
0x201E	0x0043	0x401E	Count user system start	--	--	--	--	4	RW
0x2020	0x0044	0x4020	Count battery mode event	--	--	--	--	4	RO
0x2022	0x0045	0x4022	Count user battery mode event	--	--	--	--	4	RW
0x2024	0x0046	0x4024	Count battery mode time	s	--	--	--	4	RO
0x2026	0x0047	0x4026	Count user battery time	s	--	--	--	4	RW
0x2028	0x0048	0x4028	Count actual battery mode time	s	--	--	--	4	RO
0x202A	0x0049	0x402A	Count discharge battery endvoltage	--	--	--	--	4	RO

Address [hex]			Name	Unit	Min.	Max.	Default	Size	Access
PN	EIP	EC					Byte		
0x202C	0x004A	0x402C	Count alarm device temperature	--	--	--	--	4	RO
0x202E	0x004B	0x402E	Count alarm battery temperature	--	--	--	--	4	RO
0x2030	0x004C	0x4030	Count warning battery temperature	--	--	--	--	4	RO
0x2032	0x004D	0x2032	Count alarm overload	--	--	--	--	4	RO
0x2034	0x004E	0x4034	Count alarm service	--	--	--	--	4	RO
0x2036	0x004F	0x4036	Count time after SOH expired	s	--	--	--	4	RO
0x2038	0x0050	0x4038	Status analog input	0.1 mA	--	--	--	2	RO
0x2039	0x0051	0x4039	Status battery internal resistor	mΩ	--	--	--	2	RO
0x3000	0x0052	0x5000	Status actual alarm	Code	--	--	--	4	RO
0x3002	0x0053	0x5002	Status alarm minus 1	Code	--	--	--	4	RO
0x3004	0x0054	0x5004	Status alarm minus 2	Code	--	--	--	4	RO
0x3006	0x0055	0x5006	Status alarm minus 3	Code	--	--	--	4	RO
0x3008	0x500A	0x5008	Status alarm minus 4	Code	--	--	--	4	RO
0x300A	0x0057	0x500A	Status alarm minus 5	Code	--	--	--	4	RO
0x300C	0x0058	0x500C	Status alarm minus 6	Code	--	--	--	4	RO
0x300E	0x0059	0x500E	Status alarm minus 7	Code	--	--	--	4	RO
0x3010	0x005A	0x5010	Status alarm minus 8	Code	--	--	--	4	RO
0x3012	0x005B	0x5012	Status actual warning	Code	--	--	--	4	RO
0x3014	0x005C	0x5014	Status warning minus 1	Code	--	--	--	4	RO
0x3016	0x005D	0x5016	Status warning minus 2	Code	--	--	--	4	RO
0x3018	0x005E	0x5018	Status warning minus 3	Code	--	--	--	4	RO
0x301A	0x005F	0x501A	Status warning minus 4	Code	--	--	--	4	RO
0x301C	0x0060	0x501C	Status warning minus 5	Code	--	--	--	4	RO
0x301E	0x0061	0x501E	Status warning minus 6	Code	--	--	--	4	RO
0x3020	0x0062	0x5020	Status warning minus 7	Code	--	--	--	4	RO
0x3022	0x0063	0x5022	Status warning minus 8	Code	--	--	--	4	RO
0x3024	0x0064	0x5024	Log actual input voltage	mV	--	--	--	2	RO
0x3025	0x0065	0x5025	Log actual input current	mA	--	--	--	2	RO
0x3026	0x0066	0x5026	Log actual output voltage 1	mV	--	--	--	2	RO
0x3027	0x0067	0x5027	Log actual output current	mA	--	--	--	2	RO
0x302A	0x0068	0x502A	Log actual battery voltage	mV	--	--	--	2	RO
0x302B	0x0069	0x502B	Log actual battery charge current	mA	--	--	--	2	RO
0x302D	0x006A	0x502D	Log actual battery temperature	K	--	--	--	2	RO
0x302E	0x006B	0x502E	Log status SOC	%	--	--	--	2	RO
0x302F	0x006C	0x502F	Log status SOH	%	--	--	--	2	RO
0x3030	0x006D	0x5030	Log count operation time	s	--	--	--	4	RO

16.4 Battery data

Battery 1

Address [hex]			Name	Unit	Min.	Max.	Default	Size	Access
PN	EIP	EC					Byte		
0x0002	0x006E	0x6202	Battery 1 FW version	--	--	--	--	2	RO
0x0003	0x006F	0x6203	Battery 1 serialnumber LSB	--	--	--	--	2	RO
0x0004	0x0070	0x6204	Battery 1 serialnumber 1	--	--	--	--	2	RO
0x0005	0x0071	0x6205	Battery 1 serialnumber 2	--	--	--	--	2	RO
0x0006	0x0072	0x6206	Battery 1 serialnumber MSB	--	--	--	--	2	RO
0x0007	0x0073	0x6207	Battery 1 battery type	Code	0	65535	*	2	RO
0x0011	0x0074	0x6211	Battery 1 installed capacity						
			VRLA AGM 1.3Ah	0.1Ah	0	65535	13	2	RO
			VRLA AGM 3.4Ah	0.1Ah	0	65535	34	2	RO
			VRLA AGM 7.2Ah	0.1Ah	0	65535	72	2	RO
			VRLA AGM 12Ah	0.1Ah	0	65535	120	2	RO
			VRLA AGM 38Ah	0.1Ah	0	65535	380	2	RO
			VRLA AGM WTR 13Ah	0.1Ah	0	65535	130	2	RO
			VRLA AGM WTR 26Ah	0.1Ah	0	65535	260	2	RO
			Lilon 120Wh	0.1Ah	0	65535	46	2	RO
			Lilon 924Wh	0.1Ah	0	65535	350	2	RO
0x0012	0x0075	0x6212	Battery 1 battery resistor nominal						
			VRLA AGM 1.3Ah	mΩ	0	65535	180	2	RO
			VRLA AGM 3.4Ah	mΩ	0	65535	88	2	RO
			VRLA AGM 7.2Ah	mΩ	0	65535	42	2	RO
			VRLA AGM 12Ah	mΩ	0	65535	60	2	RO
			VRLA AGM 38Ah	mΩ	0	65535	16	2	RO
			VRLA AGM WTR 13Ah	mΩ	0	65535	17	2	RO
			VRLA AGM WTR 26Ah	mΩ	0	65535	10	2	RO
			Lilon 120Wh	mΩ	0	65535	40	2	RO
			Lilon 924Wh	mΩ	0	65535	40	2	RO
0x0015	0x0076	0x6215	Battery 1 temperature alarm max						
			VRLA AGM 1.3Ah	K	0	65535	323	2	RO
			VRLA AGM 3.4Ah	K	0	65535	323	2	RO
			VRLA AGM 7.2Ah	K	0	65535	323	2	RO
			VRLA AGM 12Ah	K	0	65535	323	2	RO
			VRLA AGM 38Ah	K	0	65535	323	2	RO
			VRLA AGM WTR 13Ah	K	0	65535	343	2	RO
			VRLA AGM WTR 26Ah	K	0	65535	343	2	RO
			Lilon 120Wh	K	0	65535	338	2	RO
			Lilon 924Wh	K	0	65535	338	2	RO
0x0016	0x0077	0x6216	Battery 1 temperature alarm min						
			VRLA AGM 1.3Ah	K	0	65535	258	2	RO
			VRLA AGM 3.4Ah	K	0	65535	258	2	RO
			VRLA AGM 7.2Ah	K	0	65535	258	2	RO
			VRLA AGM 12Ah	K	0	65535	258	2	RO
			VRLA AGM 38Ah	K	0	65535	258	2	RO
			VRLA AGM WTR 13Ah	K	0	65535	2	2	RO
			Lilon 120Wh	K	0	65535	2	2	RO
			Lilon 924Wh	K	0	65535	2	2	RO
0x0017	0x0078	0x6217	Battery 1 Charge characteristic type	Code	0	65535	*	2	RO
0x0018	0x0079	0x6218	Battery 1 lifetime nominal						
			VRLA AGM 1.3Ah	month	0	65535	72	2	RO
			VRLA AGM 3.4Ah	month	0	65535	72	2	RO



Address [hex]			Name	Unit	Min.	Max.	Default	Size	Access
PN	EIP	EC					Byte		
			VRLA AGM 7.2Ah	month	0	65535	72	2	RO
			VRLA AGM 12Ah	month	0	65535	72	2	RO
			VRLA AGM 38Ah	month	0	65535	120	2	RO
			VRLA AGM WTR 13Ah	month	0	65535	180	2	RO
			VRLA AGM WTR 26Ah	month	0	65535	180	2	RO
			Lilon 120Wh	month	0	65535	180	2	RO
			Lilon 924Wh	month	0	65535	180	2	RO
0x0019	0x007A	0x6219	Battery 1 charge current max						
			VRLA AGM 1.3Ah	mA	0	65535	1000	2	RO
			VRLA AGM 3.4Ah	mA	0	65535	13600	2	RO
			VRLA AGM 7.2Ah	mA	0	65535	2880	2	RO
			VRLA AGM 12Ah	mA	0	65535	4800	2	RO
			VRLA AGM 38Ah	mA	0	65535	15200	2	RO
			VRLA AGM WTR 13Ah	mA	0	65535	5200	2	RO
			VRLA AGM WTR 26Ah	mA	0	65535	10400	2	RO
			Lilon 120Wh	mA	0	65535	10000	2	RO
			Lilon 924Wh	mA	0	65535	30000	2	RO
0x001A	0x007B	0x621A	Battery 1 charge absorption voltage						
			VRLA AGM 1.3Ah	mV	0	65535	28000	2	RO
			VRLA AGM 3.4Ah	mV	0	65535	28000	2	RO
			VRLA AGM 7.2Ah	mV	0	65535	28000	2	RO
			VRLA AGM 12Ah	mV	0	65535	28000	2	RO
			VRLA AGM 38Ah	mV	0	65535	28000	2	RO
			VRLA AGM WTR 13Ah	mV	0	65535	28000	2	RO
			VRLA AGM WTR 26Ah	mV	0	65535	28000	2	RO
			Lilon 120Wh	mV	0	65535	28200	2	RO
			Lilon 924Wh	mV	0	65535	28200	2	RO
0x001B	0x007C	0x621B	Battery 1 charge endvoltage						
			VRLA AGM 1.3Ah	mV	0	65535	27600	2	RO
			VRLA AGM 3.4Ah	mV	0	65535	27600	2	RO
			VRLA AGM 7.2Ah	mV	0	65535	27600	2	RO
			VRLA AGM 12Ah	mV	0	65535	27600	2	RO
			VRLA AGM 38Ah	mV	0	65535	27600	2	RO
			VRLA AGM WTR 13Ah	mV	0	65535	27200	2	RO
			VRLA AGM WTR 26Ah	mV	0	65535	27200	2	RO
			Lilon 120Wh	mV	0	65535	28200	2	RO
			Lilon 924Wh	mV	0	65535	28200	2	RO
0x001C	0x007D	0x621C	Battery 1 charge temperature coefficient						
			VRLA AGM 1.3Ah	mV/K	0	65535	42	2	RO
			VRLA AGM 3.4Ah	mV/K	0	65535	42	2	RO
			VRLA AGM 7.2Ah	mV/K	0	65535	42	2	RO
			VRLA AGM 12Ah	mV/K	0	65535	42	2	RO
			VRLA AGM 38Ah	mV/K	0	65535	42	2	RO
			VRLA AGM WTR 13Ah	mV/K	0	65535	18	2	RO
			VRLA AGM WTR 26Ah	mV/K	0	65535	18	2	RO
			Lilon 120Wh	mV/K	0	65535	0	2	RO
			Lilon 924Wh	mV/K	0	65535	0	2	RO
0x001D	0x007E	0x621D	Battery 1 discharge endvoltage						
			VRLA AGM 1.3Ah	mV	0	65535	19200	2	RO
			VRLA AGM 3.4Ah	mV	0	65535	19200	2	RO
			VRLA AGM 7.2Ah	mV	0	65535	19200	2	RO
			VRLA AGM 12Ah	mV	0	65535	19200	2	RO
			VRLA AGM 38Ah	mV	0	65535	19200	2	RO





Address [hex]			Name	Unit	Min.	Max.	Default	Size	Access
PN	EIP	EC							
			VRLA AGM WTR 13Ah	mV	0	65535	19200	2	RO
			VRLA AGM WTR 26Ah	mV	0	65535	19200	2	RO
			Lilon 120Wh	mV	0	65535	20000	2	RO
			Lilon 924Wh	mV	0	65535	20000	2	RO
0x001E	0x007F	0x621E	Battery 1 discharge current max						
			VRLA AGM 1.3Ah	mA	0	65535	15000	2	RO
			VRLA AGM 3.4Ah	mA	0	65535	25000	2	RO
			VRLA AGM 7.2Ah	mA	0	65535	50000	2	RO
			VRLA AGM 12Ah	mA	0	65535	50000	2	RO
			VRLA AGM 38Ah	mA	0	65535	50000	2	RO
			VRLA AGM WTR 13Ah	mA	0	65535	50000	2	RO
			VRLA AGM WTR 26Ah	mA	0	65535	50000	2	RO
			Lilon 120Wh	mA	0	65535	30000	2	RO
			Lilon 924Wh	mA	0	65535	65535	2	RO
0x0080	0x0080	0x6280	Battery 1 temperature warning max						
			VRLA AGM 1.3Ah	K	0	65535	313	2	RO
			VRLA AGM 3.4Ah	K	0	65535	313	2	RO
			VRLA AGM 7.2Ah	K	0	65535	313	2	RO
			VRLA AGM 12Ah	K	0	65535	313	2	RO
			VRLA AGM 38Ah	K	0	65535	313	2	RO
			VRLA AGM WTR 13Ah	K	0	65535	333	2	RO
			VRLA AGM WTR 26Ah	K	0	65535	333	2	RO
			Lilon 120Wh	K	0	65535	323	2	RO
			Lilon 924Wh	K	0	65535	323	2	RO
0x0081	0x0081	0x6281	Battery 1 temperature warning min						
			VRLA AGM 1.3Ah	K	0	65535	273	2	RO
			VRLA AGM 3.4Ah	K	0	65535	273	2	RO
			VRLA AGM 7.2Ah	K	0	65535	273	2	RO
			VRLA AGM 12Ah	K	0	65535	273	2	RO
			VRLA AGM 38Ah	K	0	65535	273	2	RO
			VRLA AGM WTR 13Ah	K	0	65535	248	2	RO
			VRLA AGM WTR 26Ah	K	0	65535	248	2	RO
			Lilon 120Wh	K	0	65535	248	2	RO
			Lilon 924Wh	K	0	65535	248	2	RO
0x0085	0x0082	0x6285	Battery 1 discharge endvoltage low current						
			VRLA AGM 1.3Ah	mV	0	65535	21000	2	RO
			VRLA AGM 3.4Ah	mV	0	65535	21000	2	RO
			VRLA AGM 7.2Ah	mV	0	65535	21000	2	RO
			VRLA AGM 12Ah	mV	0	65535	21000	2	RO
			VRLA AGM 38Ah	mV	0	65535	21000	2	RO
			VRLA AGM WTR 13Ah	mV	0	65535	20400	2	RO
			VRLA AGM WTR 26Ah	mV	0	65535	20400	2	RO
			Lilon 120Wh	mV	0	65535	65535	2	RO
			Lilon 924Wh	mV	0	65535	65535	2	RO
0x0087	0x0083	0x6287	Battery 1 status SOC	%	--	--	--	2	RO
0x0088	0x0084	0x6288	Battery 1 status SOH	%	--	--	--	2	RO
0x00A3	0x0085	0x62A3	Battery 1 status actual temperature	K	--	--	--	2	RO
0x00A5	0x0086	0x62A5	Battery 1 status fuse	Code	--	--	--	2	RO
0x00A7	0x0087	0x62A7	Battery 1 status actual internal voltage	mV	--	--	--	2	RO
0x42A8	0x0088	0x62A8	Battery 1 status actual block voltage	mV	--	--	--	2	RO



The configuration of battery data 2 to 5 is identical to that of battery data 1. The following battery data is only provided as an example due to the extensive addressing of the battery data. Observe the corresponding address ranges.

**Battery 2**

Address [hex]			Name	Unit	Min.	Max.	Default	Size	Access
PN	EIP	EC					Byte		
0x0002	0x0089	0x6302	Battery 2 FW version	--	--	--	--	2	RO
0x0003	0x008A	0x6303	Battery 2 serialnumber LSB	--	--	--	--	2	RO
0x0004	0x008B	0x6304	Battery 2 serialnumber 1	--	--	--	--	2	RO
0x0005	0x008C	0x6305	Battery 2 serialnumber 2	--	--	--	--	2	RO
0x0006	0x008D	0x6306	Battery 2 serialnumber MSB	--	--	--	--	2	RO
...	...	...	...						

**Battery 3**

Address [hex]			Name	Unit	Min.	Max.	Default	Size	Access
PN	EIP	EC					Byte		
0x0002	0x00A4	0x6402	Battery 3 FW version	--	--	--	--	2	RO
0x0003	0x00A5	0x6403	Battery 3 serialnumber LSB	--	--	--	--	2	RO
0x0004	0x00A6	0x6404	Battery 3 serialnumber 1	--	--	--	--	2	RO
0x0005	0x00A7	0x6405	Battery 3 serialnumber 2	--	--	--	--	2	RO
0x0006	0x00A8	0x6406	Battery 3 serialnumber MSB	--	--	--	--	2	RO
...	...	...	...						

**Battery 4**

Address [hex]			Name	Unit	Min.	Max.	Default	Size	Access
PN	EIP	EC					Byte		
0x0002	0x00BF	0x6502	Battery 4 FW version	--	--	--	--	2	RO
0x0003	0x00C0	0x6503	Battery 4 serialnumber LSB	--	--	--	--	2	RO
0x0004	0x00C1	0x6504	Battery 4 serialnumber 1	--	--	--	--	2	RO
0x0005	0x00C2	0x6505	Battery 4 serialnumber 2	--	--	--	--	2	RO
0x0006	0x00C3	0x6506	Battery 4 serialnumber MSBB	--	--	--	--	2	RO
...	...	...	...						

**Battery 5**

Address [hex]			Name	Unit	Min.	Max.	Default	Size	Access
PN	EIP	EC					Byte		
0x0002	0x00DA	0x6602	Battery 5 FW version	--	--	--	--	2	RO
0x0003	0x00DB	0x6603	Battery 5 serialnumber LSB	--	--	--	--	2	RO
0x0004	0x00DC	0x6604	Battery 5 serialnumber 1	--	--	--	--	2	RO
0x0005	0x00DD	0x6605	Battery 5 serialnumber 2	--	--	--	--	2	RO
0x0006	0x00DE	0x6606	Battery 5 serialnumber MSB	--	--	--	--	2	RO
...	...	...	...						

16.5 Code Set Parameters 0x1040

Bit	Negation of signal	Default
0	Set DO1	0
1	Set DO 2	0
2	Set DO 3	0
3	Reserved	--
4	Enable/disable charge current control	0
5	Enable/disable balancing function	0
6	Set device factory settings	0
7	Reserved	0
8	Activate systemtest	0
9	Activate battery capacity test	0
10	Confirm battery change	0
11	Enable/disbale output	0
12	Enable/disable autonomic start function	1
13	Enable/disable emergency power mode	0
14	Enable/disable dynamic backup threshold	0
15	Reserved	0
16	Use charge current from LIN (auto) or user	0
17	Use charge voltage threshold from LIN (auto) or user	0
18	Use discharge voltage threshold from LIN (auto) or user	0
19	Switch to service mode by button/software	0
20	Enable/disable service mode button	1
21	Activate quality test of battery	0
22	Enable complete read of static battery data	0
23	Enable remote function in main power mode	1
24	Enable remote function in battery mode	1
25	UPS wiring standalone/parallel	0
26	Enable energy saving 1: LEDs off during battery mode	0
27	Enable energy saving 2: DOs off during battey mode	0
28	Enable energy saving 3: Communication off during battery mode	0
29	Enable/disable output after SOC reached	0
30	Enable/disable battery check	0
31	Enable/disable remote signal by software	0

16.6 Set Signaling Code DO 1 0x1042

Bit	Description	Default
0	Negation of signal	0
1	Collective battery alarm	1
2	Collective alarm to replace battery	0
3	Battery not detected	0
4	Capacity test negative	0
5	Battery end of lifetime - SOH value too low	0
6	Battery end of lifetime - Residual lifetime reached	0
7	Battery end of lifetime - User replace time reached	0
8	Collective alarm battery low	0
9	Reserved	0
10	Reserved	0
11	Reserved	0
12	Collective alarm device failure	1
13	Output 1 failed	0
14	Reserved	0
15	Service mode is active	0
16	Collective battery warning	0
17	Collective warning battery is discharged	0
18	Reserved	0
19	Reserved	0
20	Reserved	0
21	Collective warning device function not optimal	0
22	External charger disabled	0
23	Battery mode active	0
24	Battery is charging	0
25	Remote signal	0
26	Event PC shutdown triggered	0
27	Event 1 battery mode triggered	0
28	Event 2 battery mode triggered	0
29	Buffer ready signal	0
30	Input voltage is in valid range	0
31	Status DI2: Boost signal	0

16.7 Set Signalling Code DO 2 0x1044

Bit	Description	Default
0	Negation of signal	0
1	Collective battery alarm	0
2	Collective alarm to replace battery	0
3	Battery not detected	0
4	Capacity test negative	0
5	Battery end of lifetime - SOH value too low	0
6	Battery end of lifetime - Residual lifetime reached	0
7	Battery end of lifetime - User replace time reached	0
8	Collective alarm battery low	0
9	Reserved	0
10	Reserved	0
11	Reserved	0
12	Collective alarm device failure	0
13	Output 1 failed	0
14	Reserved	0
15	Service mode is active	0
16	Collective battery warning	0
17	Collective warning battery is discharged	0
18	Reserved	0
19	Reserved	0
20	Reserved	0
21	Collective warning device function not optimal	0
22	External charger disabled	0
23	Battery mode active	1
24	Battery is charging	0
25	Remote signal	0
26	Event PC shutdown triggered	0
27	Event 1 battery mode triggered	0
28	Event 2 battery mode triggered	0
29	Buffer ready signal	0
30	Input voltage is in valid range	0
31	Status DI2: Boost signal	0



**16.8 Set Signalling Code DO 3 0x1046**

Bit	Description	Default
0	Negation of signal	0
1	Collective battery alarm	0
2	Collective alarm to replace battery	0
3	Battery not detected	0
4	Capacity test negative	0
5	Battery end of lifetime - SOH value too low	0
6	Battery end of lifetime - Residual lifetime reached	0
7	Battery end of lifetime - User replace time reached	0
8	Collective alarm battery low	0
9	Reserved	0
10	Reserved	0
11	Reserved	0
12	Collective alarm device failure	0
13	Output 1 failed	0
14	Reserved	0
15	Service mode is active	0
16	Collective battery warning	0
17	Collective warning battery is discharged	0
18	Reserved	0
19	Reserved	0
20	Reserved	0
21	Collective warning device function not optimal	0
22	External charger disabled	0
23	Battery mode active	0
24	Battery is charging	0
25	Remote signal	0
26	Event PC shutdown triggered	0
27	Event 1 battery mode triggered	0
28	Event 2 battery mode triggered	0
29	Buffer ready signal	1
30	Input voltage is in valid range	0
31	Status DI2: Boost signal	0

**16.9 Code Set Function Code DI 1 0x104A**

Bit	Description	Default
0	Reserved	0
1	Remote in use	1
2	Turn device output off	0
3	Reserved	0
4	Reserved	0
5	Disable/enable charger	0
6	Reserved	0
7	Reserved	0
8	Reserved	0
9	Reserved	0
10	Reserved	0

**16.10 Code Set Function Code DI 2 0x104B**

Bit	Description	Default
0	Reserved	0
1	Reserved	0
2	Reserved	0
3	Digital boost active	1
4	Analog boost active	0
5	Reserved	0
6	Reserved	0
7	Reserved	0
8	Reserved	0
9	Power supply data input digital	0
10	Reserved	0
10	Power supply data input analog	0

**16.11 Code Set User Installed Peripherie 0x1063**

Bit	Description
0 ... 3	Number of batteries
4, 5	Number of chargers
6 ... 31	Number of additional devices

**16.12 Code Set Mode Selector Switch 0x1074**

Bit	Description
7 ... 10	0000 = permanently
	0001 = CUSTOM (0.5 min)
	0010 = 1 min.
	0011 = 2 min.
	0100 = 3 min.
	0101 = 5 min.
	0110 = 10 min.
	0111 = 15 min.
	1000 = 20 min.
	1001 = PC-Mode

**16.13 Code Set Enable/Disable Function 0x1076**

Bit	Description	Default
0	Enable/disable 0x104D SET_CHARGE_CURRENT	1
1	Enable/disable 0x1054 SET_MAX_CURRENT_OUTPUT_1	0
2	Reserved	0
3	Enable/disable 0x1061 SET_THRESHOLD_BUFFER_READY	0
4	Enable/disable 0x1062 SET_BAT_MODE_USABLE_CAPACITY	0
5	Enable/disable 0x1068 SET_BAT_ALARM_USER_REPLACE_TIME	0
6	Enable/disable 0x1069 SET_BAT_ALARM_SOC_VOLTAGE	1
7	Enable/disable 0x106A SET_BAT_ALARM_SOC_PERCENT	1
8	Enable/disable 0x106B SET_BAT_ALARM_SOC_TIME	0
9	Enable/disable 0x106C SET_BAT_ALARM_SOH_PERCENT	0
10	Enable/disable 0x106D SET_BAT_ALARM_SOH_TIME	1
11	Enable/disable 0x106E SET_BAT_WARNING_SOC_VOLTAGE	0
12	Enable/disable 0x106F SET_BAT_WARNING_SOC_PERCENT	0
13	Enable/disable 0x1070 SET_BAT_WARNING_SOC_TIME	0
14	Enable/disable 0x1071 SET_BAT_WARNING_SOH_PERCENT	0
15	Enable/disable 0x1072 SET_BAT_WARNING_SOH_TIME	0
16	Enable/disable 0x1073 SET_BAT_WARNING_DELTA_TEMP	0
17	Enable/disable 0x1074 SET_MODE_SELECTOR_SWITCH	0

**16.14 Code Status Functions 0x2000**

Bit	Description	Comment
0	Startup	Device is starting
1	Main Power Mode	Device is in mains mode
2	Battery Mode	Device is in battery mode
3	Output	Output of device is on/off
4	Boost	Device is in boost mode
5	Charger	Charger of device is on/off
6	Battery Communication	Communication to batteries is active/inactive
7	Status Bat Communication (Bit 6 = 1)	Status communication to batteries: 0=addressing, 1=normal communication
8	Autonomic Start	Autonomic start input is open/closed
9	Remote	Remote DI connected/disconnected
10	Remote use	Remote is enabled/disabled
11	Boost	Power supply is in boost mode
12	Reserved	--
13	Phoenix Extra Charger	Phoenix Contact additional charger is connected
14	Service	Device is in service mode
15	Bat Delayed 1	Battery mode delay time 1 is active
16	Bat Delayed 2	Battery mode delay time 2 is active
17	Bat Delayed 3	Battery mode delay time 3 is active
18	External Charger Not Phoenix	External charger active/inactive
19	Buffer Ready	Connected energy storage is ready to buffer
20	Button use	Service button enabled/disabled
21	Selector Switch use	Service button enabled/disabled
22	System Test	Service button enabled/disabled
23	Battery Capacity Test	Battery capacity test active/inactive
24	Battery present	Energy storage connected/disconnected
25	SOC initialised	State of charge initialized
26	Trigger Log Data	New log data available

**16.15 Code Status Interface 0x2002**

Bit	Description	Comment
0	DO1	DO1 is active/inactive
1	DO2	DO2 is active/inactive
2	DO3	DO3 is active/inactive
3	Reserved	--
4	DI1	DI1 is active/inactive
5	DI2	DI2 is active/inactive
6	DI3	DI3 is active/inactive
7	Mode Selector Switch	Mode selector switch Bit 1
8	Mode Selector Switch	Mode selector switch Bit 2
9	Mode Selector Switch	Mode selector switch Bit 3
10	Mode Selector Switch	Mode selector switch Bit 4
11	Service button pressed	Service button pressed/not pressed
12	LED green	Green LED is on/off
13	LED yellow	Yellow LED is on/off
14	LED red	Red LED is on/off
15	LED Bargraph red	Red bargraph LED is on/off
16	LED Bargraph green 1	Green bargraph LED 1 is on/off
17	LED Bargraph green 2	Green bargraph LED 2 is on/off
18	LED Bargraph green 3	Green bargraph LED 3 is on/off
19	LED Bargraph green 4	Green bargraph LED 4 is on/off
20	LED Bargraph green 5	Green bargraph LED 5 is on/off
21	SFB Input	SFB input is active/inactive

**16.16 Code Status Installed Peripherie 0x2015**

Bit	Description
0 ... 3	Number of batteries
4, 5	Number of charger
6, 7	Reserved
8 ... 15	Reserved

16.17 Code Status Actual Alarms 0x3000

Bit	Description
0	--
1	Alarm battery (collective alarm Bit 2 - Bit 21)
2	Replace battery (collective alarm Bit 7 - Bit 17 & Bit 20)
3	Battery not detected (battery presence test negative)
4	Fuses check negative (alarm from battery modul via LIN)
5	LIN detected battery technologies are inconsistent
6	Battery temperature - temperature out of battery max values ( e.g. VRLA +60 °C)
7	Battery end of lifetime - Exhausted battery has been installed - First fast quality test negative (controls battery voltage with and without load; internal discharging with resistor)
8	Battery end of lifetime exhausted battery has been installed - First discharge reference test with internal resistor negative
9	Battery end of lifetime - Battery exhausted - Discharge test with internal resistor compared to reference test is negative
10	Battery end of lifetime - Battery voltage low during charging (!!!OLD!!! EN54-4 Battery voltage has to be over 80% of discharge end voltage after 30 minutes of charging)
11	Battery end of lifetime - Charging time exceeded - Battery has been charged too long
12	Battery end of lifetime - Battery exhausted - Difference of the battery block voltages too high
13	Capacity test negative - Battery capacity (SOC) <80 %, after complete discharge test
14	Capacity test negative - compared to runtime choosen through mode selector
15	Battery end of lifetime - SOH under threshold - SOH value too low (connected to 0106A)
16	Battery end of lifetime - Residual lifetime reached - Lifetime too low (connected to 0106B)
17	Battery end of lifetime - User replace time reached - Battery user time is up (counts backwards)(connected to 0x2026)
18	Battery is discharged, (collectice alarm Bit 19 - Bit 21)
19	Battery low - Alarm battery voltage under threshold, User value (connected to 0x1069)
20	Battery low - Alarm battery charge under threshold, User value (connected to 0x106A)
21	Battery low - Alarm residual time under threshold, User value (connected to 0x106B)
22	Reserved
23	Device fail (collectice alarm Bit 24 - 28)
24	Output 1 fail (e.g. Overload cutoff)
25	Output 2 fail (e.g. Overload cutoff)
26	Charger fail - internal test
27	Various measurement values (internal FW/HW troubleshooting)
28	Out of Specification - overheated component (i.e. internal ultra caps)
29	Reserved
30	Service mode is active
31	Reserved



**16.18 Code Status Actual Warnings 0x3012**

Bit	Description
0	--
1	Warning battery (collective warning Bit 2 - 14)
2	Battery communication fault (e.g. no signal or timeouts)
3	Service mode quit without battery change
4	LIN detected more / less batteries than user registered
5	Reserved
6	Battery temperature - temperature out of battery nominal values ( e.g. VRLA +40 °C)
7	LIN detected additional installed battery
8	Detected battery capacities are inconsistent
9	Connected battery capacity too high; long recharging time
10	Connected battery capacity too small; can't supply full output current
11	High temperature drop between battery modules
12	Battery end of lifetime - SOH under threshold - SOH value too low (connected to 0x1071)
13	Battery end of lifetime - Residual lifetime reached - Lifetime too low (connected to 0x1072)
14	Any user counter reached end value
15	Reserved
16	Battery is discharged (collective warning Bit 17 - 19)
17	Battery low - Warning battery voltage under threshold, user value (connected to 0x106E)
18	Battery low - Warning battery charge under threshold, user value (connected to 0x106F)
19	Battery low - Warning residual time under threshold, user value (connected to 0x1070)
20	Reserved
21	Reserved
22	Device function are not optimal - (collective warning Bit 23 - 29)
23	Phoenix extra charger communication fault (e.g. no signal or timeouts)
24	Communication fault to host (i.e. Ethernet or USB)
25	Remote connected to GND
26	Any button or mode selector deactivated
27	Out of specification - out of ambient condition
28	External charger disabled (not PxC Charger)
29	Battery capacity test active
30	Reserved
31	Reserved

**16.19 Code Battery 1 Battery Type 0x4\_07**

Code (dec)	Battery type
1000	VRLA AGM 1.3Ah
1001	VRLA AGM 3.4Ah
1002	VRLA AGM 7.2Ah
1003	VRLA AGM 12Ah
1004	VRLA AGM 38Ah
6000	VRLA AGM WTR 13Ah
6001	VRLA AGM WTR 26Ah
11000	Lilon 120Wh
11001	Lilon 924Wh

16.20 Code Battery 1 Charge Characteristic Type 0x4\_17



0 = IU loading characteristic, 1 = IU0U loading characteristic

Code	Battery type
1	VRLA AGM 1.3Ah
1	VRLA AGM 3.4Ah
1	VRLA AGM 7.2Ah
1	VRLA AGM 12Ah
1	VRLA AGM 38Ah
1	VRLA AGM WTR 13Ah
1	VRLA AGM WTR 26Ah
0	Lilon 120Wh
0	Lilon 924Wh

16.21 Code Battery Status Fuse 0x4\_A5

Code	Description
23861	Fuse broken
65535	Fuse OK